

IN-LINE MECHANICAL PRODUCTION TEST EQUIPMENT FOR CRACK DETECTION IN PERMANENT MAGNETS AND MAGNET BLANKS

S. Spasic (SENIS),
Yu Miao (MAS-Intelligent Technology),
Zhen Xu (GMW),
Ian Walker (GMW)

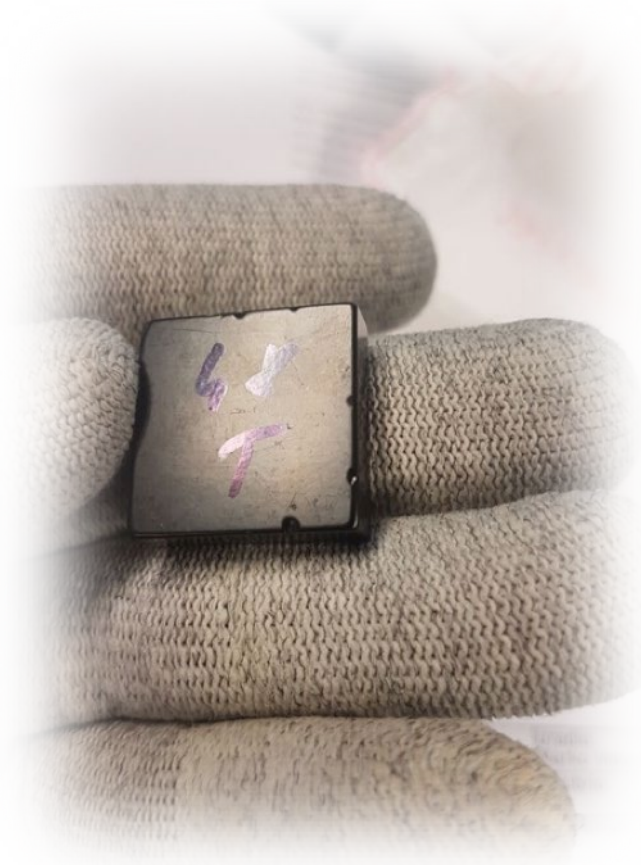

**MAGNETICS
2020**



CRACKS CAUSE COSTS!

- Magnets with cracks or defects on surface or inside inhomogeneities can break during magnetizing, processing, assembly or in operation.
- Crack induced failure inside the magnet system can be dangerous, e.g. high continuous torque motor
- It might be costly to replace the complete assembled magnet system, such as motor/rotor, sensor systems
- Detection of cracks during the production process can improve the yield and reduce the maintenance costs.



HOW DO CRACKS LOOK LIKE?

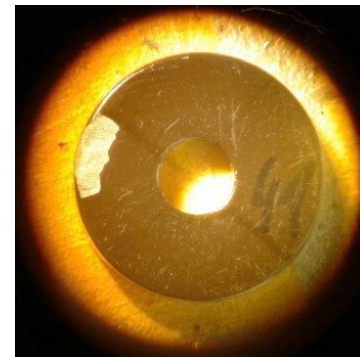
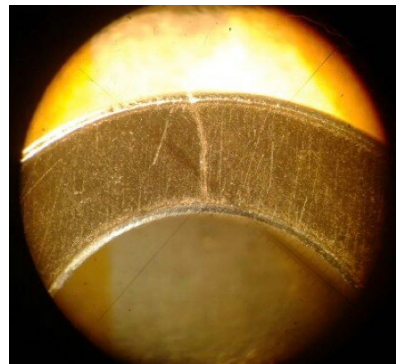
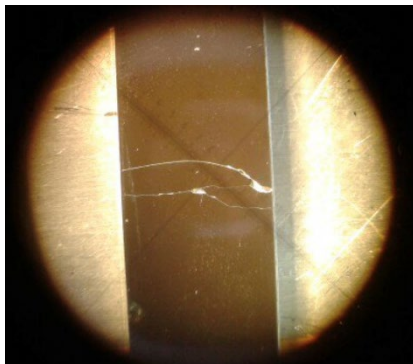
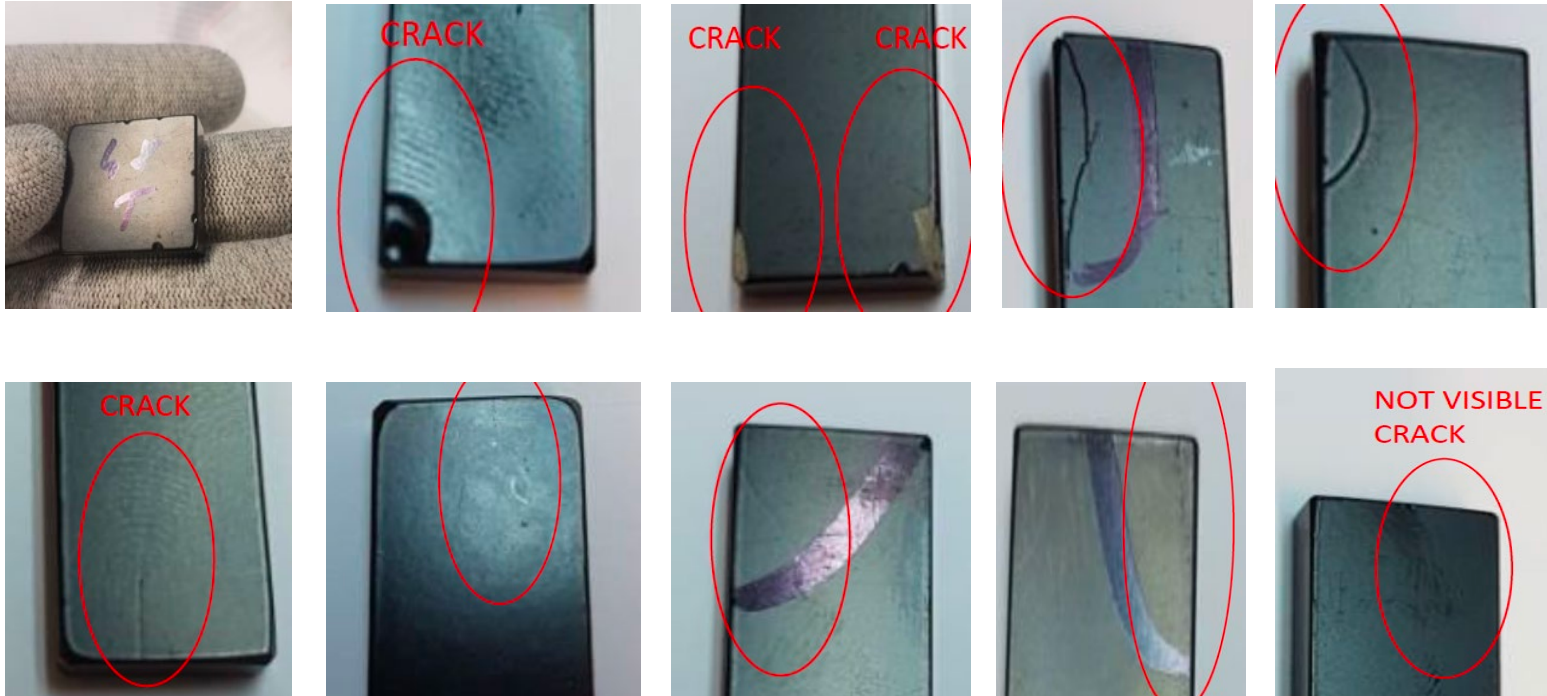

EDDY CURRENT - CRACK DETECTION

- Alternating current injected into a coil creates a magnetic field.
- When the coil is placed over a conductive part, opposed alternating currents are generated.
- Defects in the part disturb the path of the eddy currents.
- This disturbance can be measured by pickup coils, either through single coil or differential pick coils.

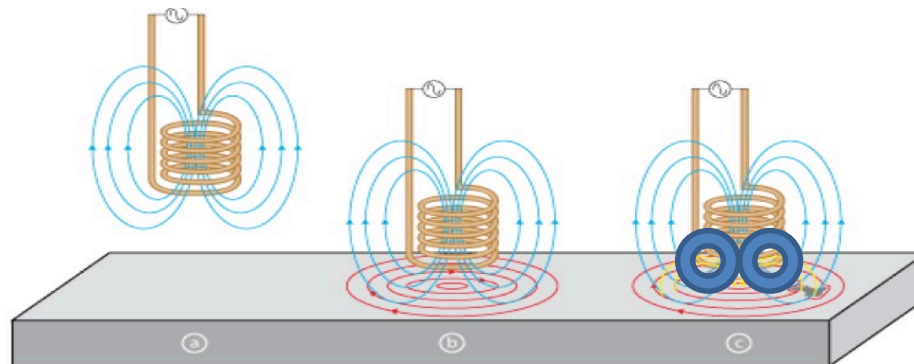

INFLUENCING FACTORS

- Conductivity of the target plate
- Permeability of the target plate
- Temperature of the target plate
- Coil geometry
- Operating frequency (excitation)



Probe Design and Simulation

skin depth(mm) of NdFeB

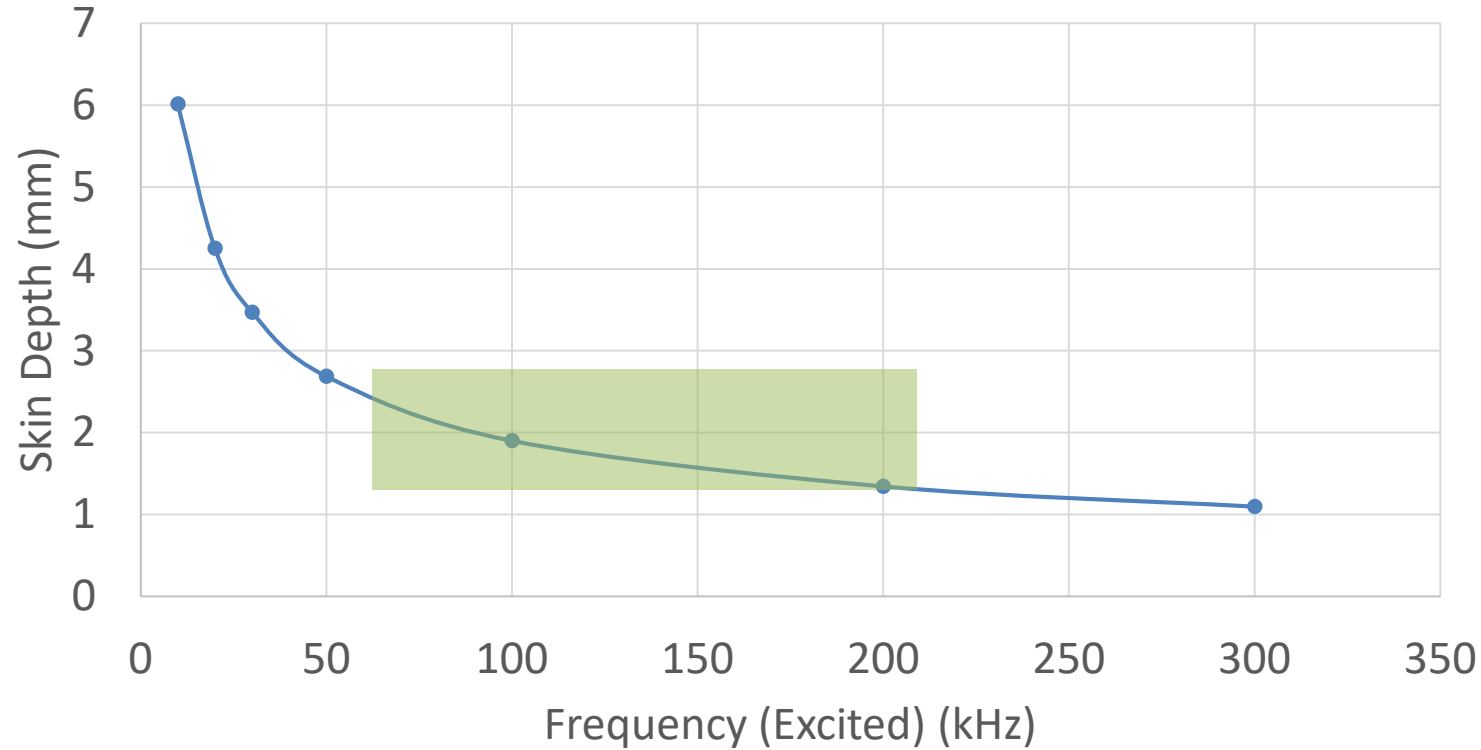

$$J = J_S e^{-(1+j)d/\delta}$$

$$\delta = \sqrt{\frac{2}{\omega\mu\sigma}}$$

d: Distance relative to sample surface
 J_S : Surface density

Properties if NdFeB:

Conductivity: 6.67E+05 S/m
 Relative permeability: 1.05

Sensor Configurations: 20kHz to 220kHz in the steps of 10kHz



Simulation Example

Sample Size: 100mm*40mm

Parameters			
Name	Expression	Value	Description
a2	6.15[mm]	0.00615 m	Inner Radius of Coil
a1	12.4[mm]	0.0124 m	Outer Radius of Coil
b	6.15[mm]	0.00615 m	Length of Coil
N	3790	3790	Number of Turns
l	0.88[mm]	8.8E-4 m	Lift-Off
Sigma_Test	6.67e5[S/m]	6.67E5 S/m	Conductivity of Test Spec...
Thickness_Test	6[mm]	0.006 m	Thickness of Test Specim...
Height_Defect	3[mm]	0.003 m	Height of Defect
Depth_Defect	12.6[mm]	0.0126 m	Depth of Defect
Width_Defect	0.28[mm]	2.8E-4 m	Width of Defect
Freq	200000[Hz]	2E5 Hz	Frequency
Position	0[mm]	0 m	Initial Position of Coil

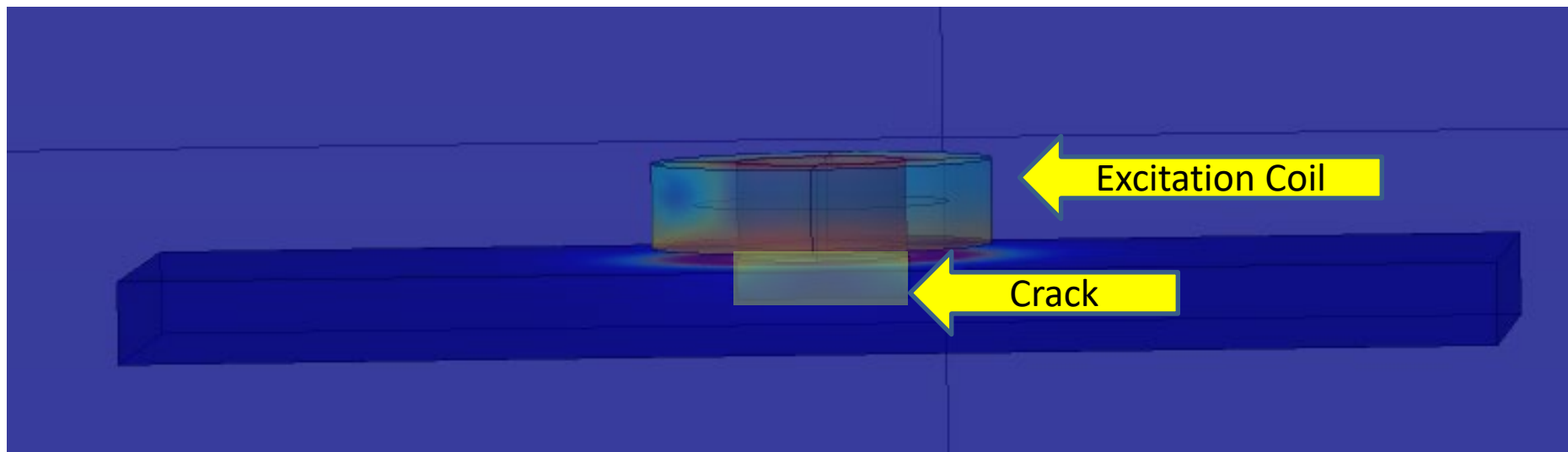
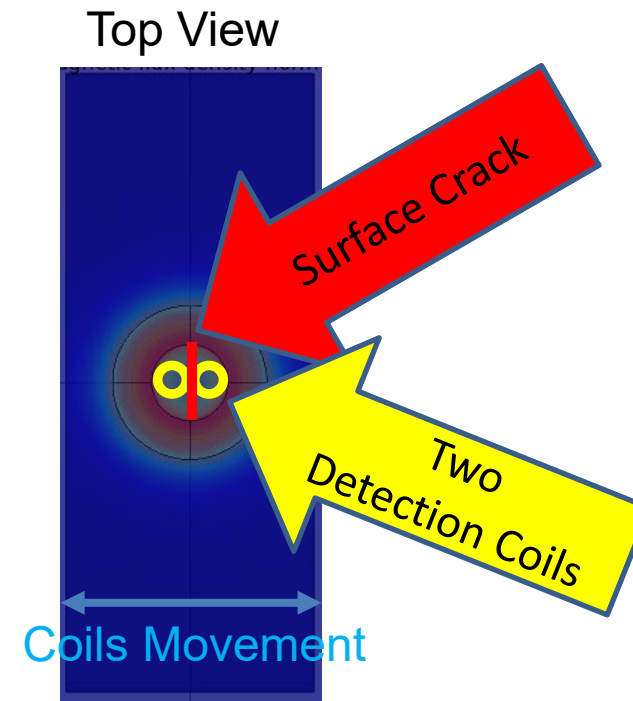

Side View

Current Density Distribution

Position: -4mm

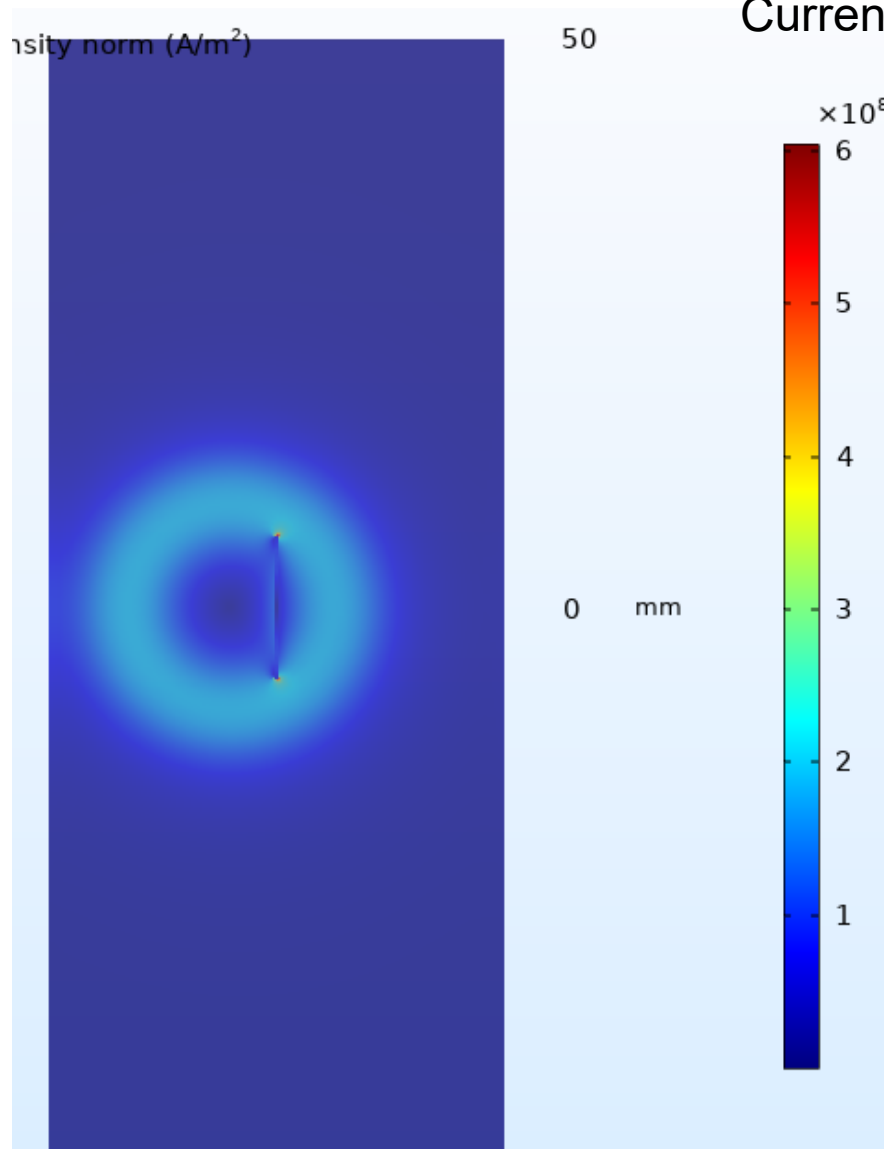

Crack

Current Density (A/m²)

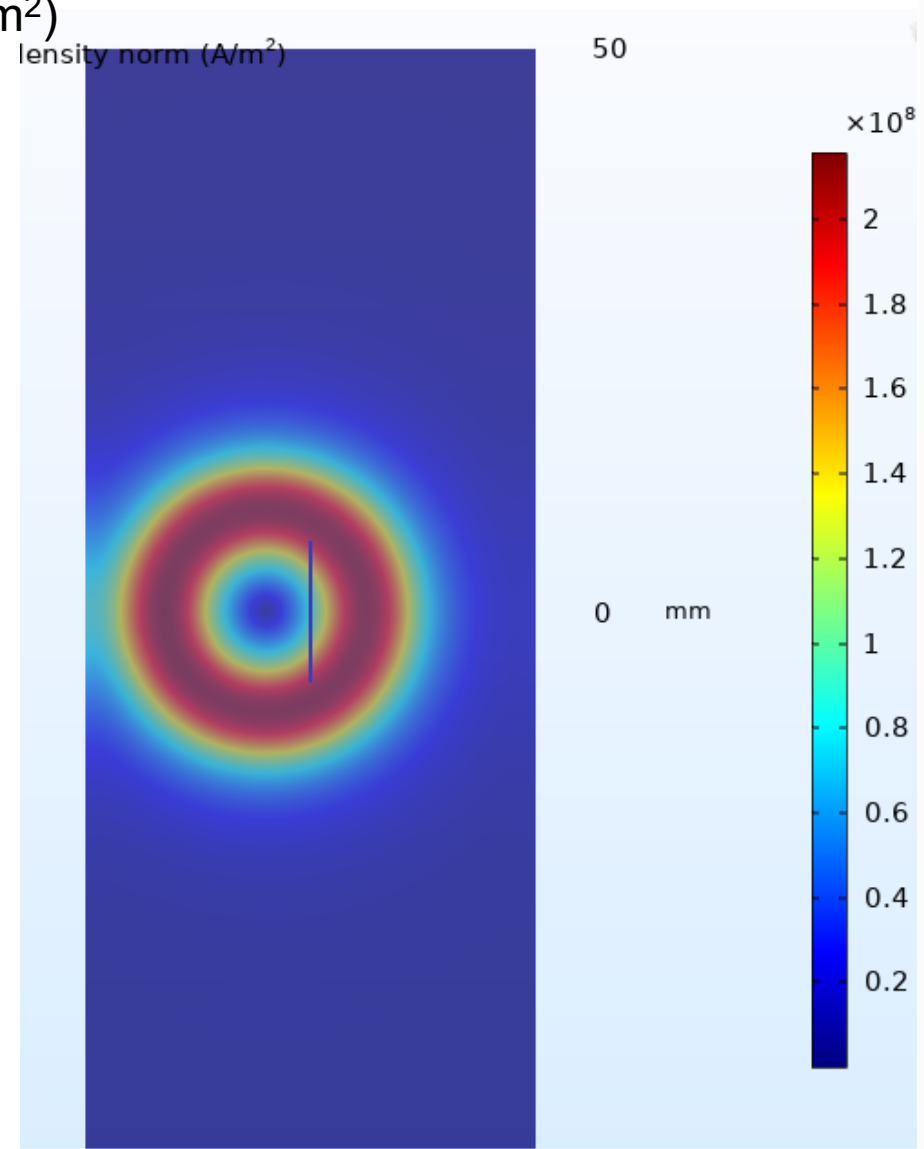

No Crack



Magnetic Flux Density on sample surface

Crack

Position: -4mm

No Crack

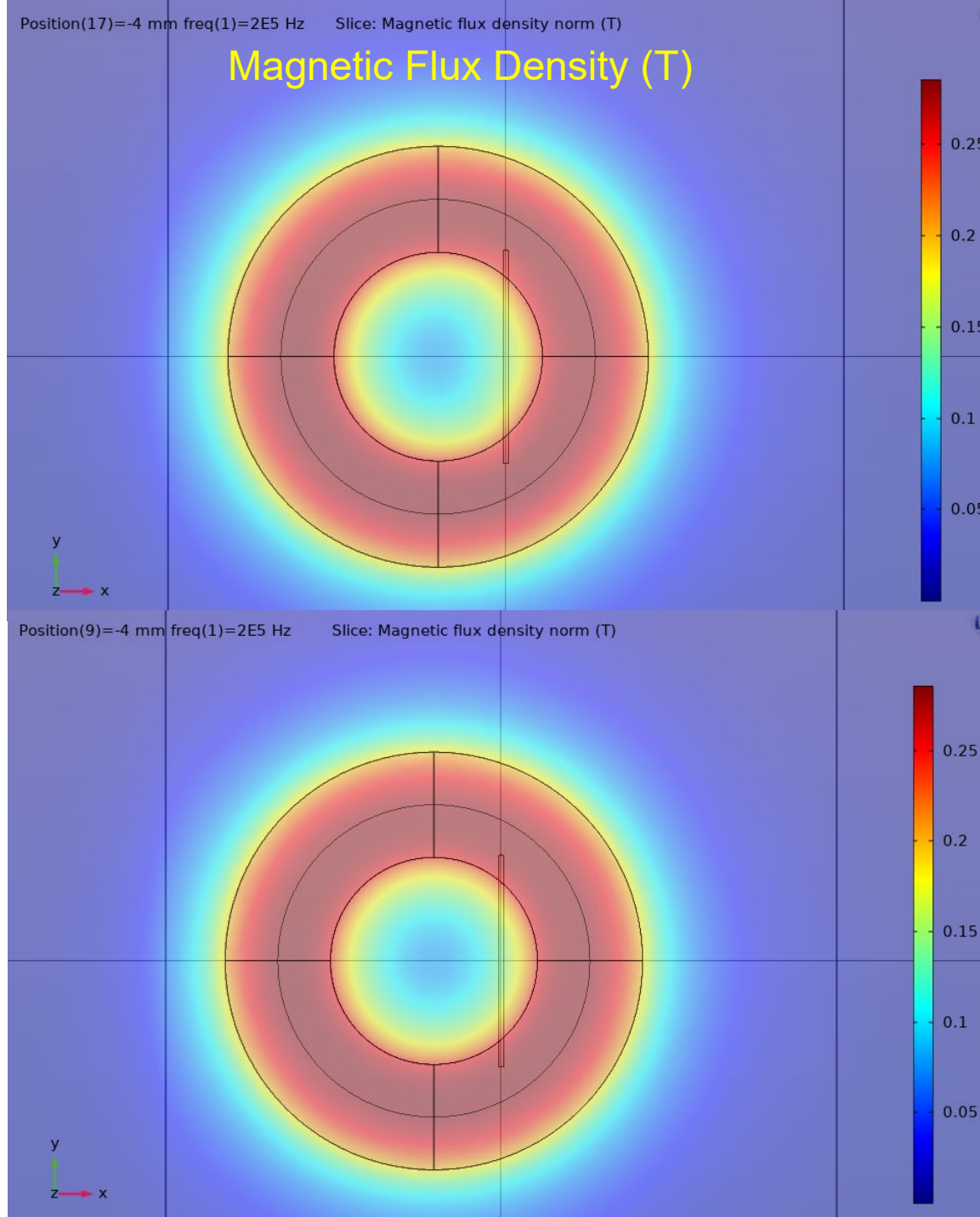

Current Density Distribution

Position: 4mm

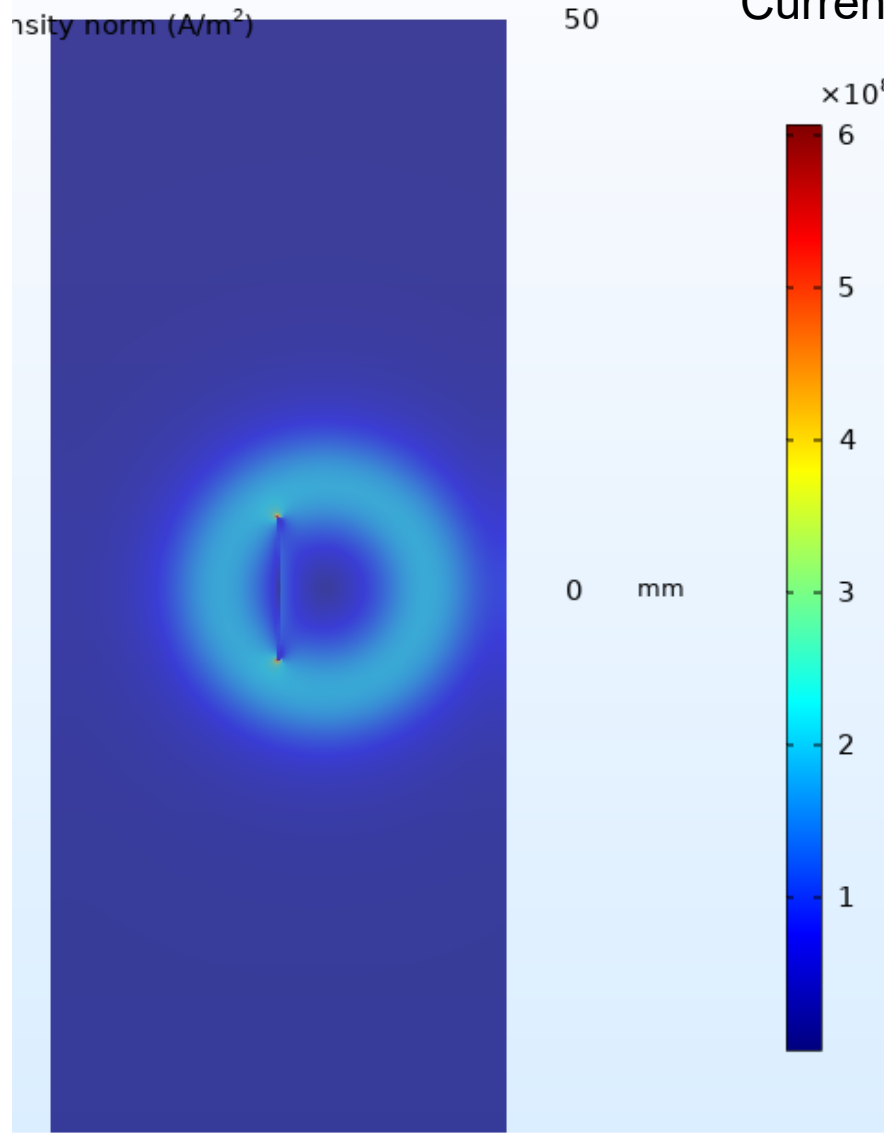

Crack

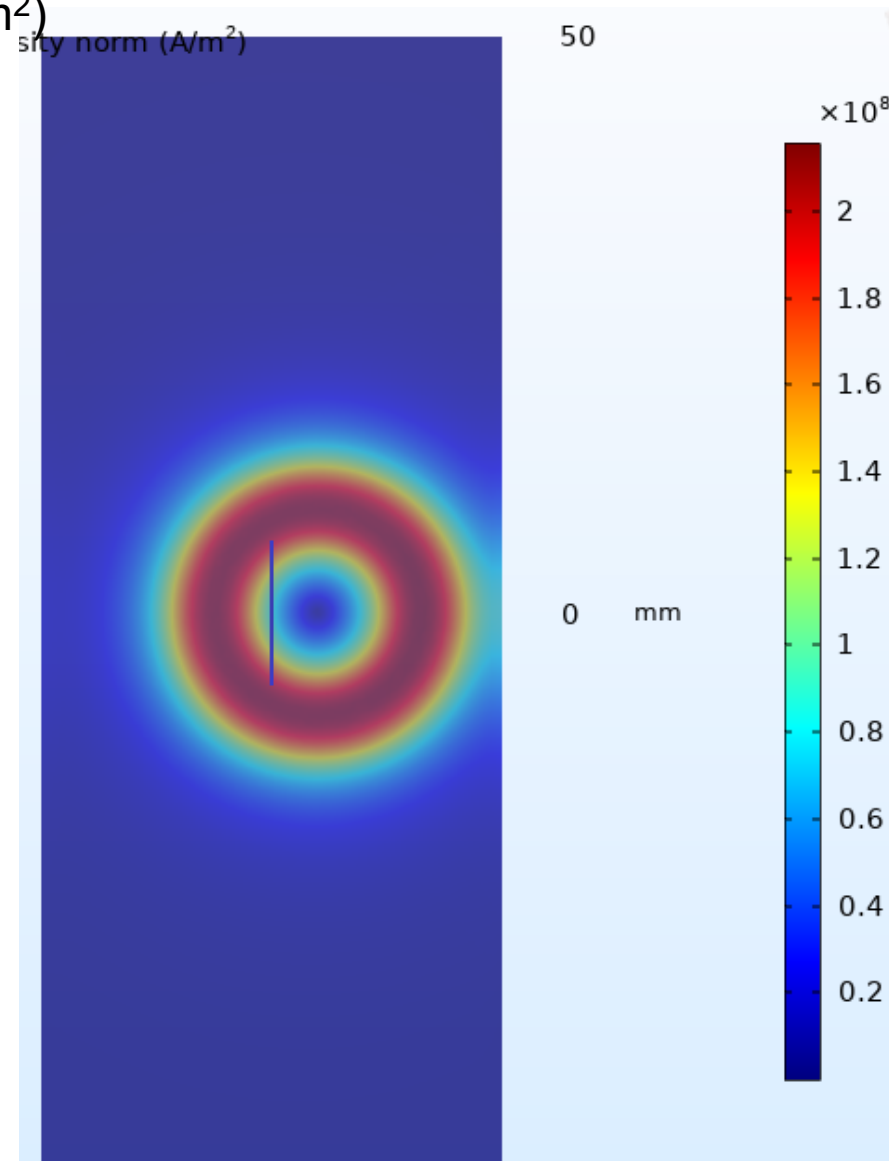

No Crack

Crack & No Crack

$$V = -\frac{d\phi}{dt} = -\frac{d(N \cdot \vec{B} \cdot \vec{S})}{dt} = -N \cdot f \cdot \vec{B} \cdot \vec{S}$$

Sum_two_coils With Crack

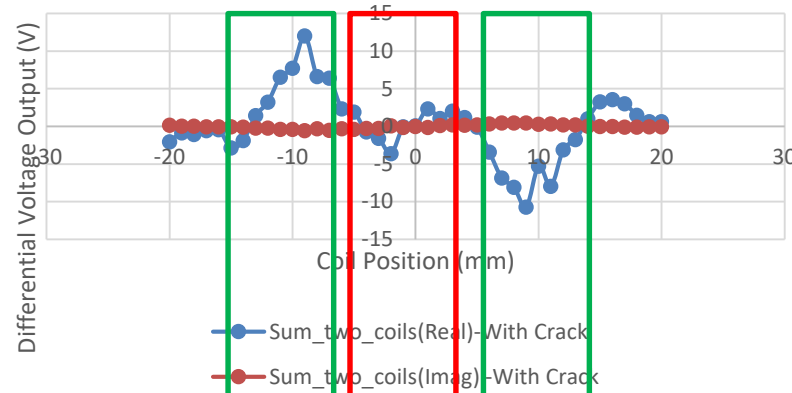

Crack Influences

Sum_two_coils Without Crack

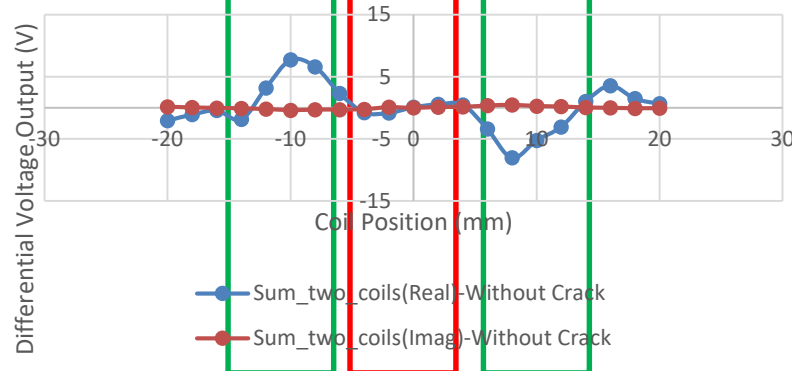

Sample Edge Influences

Sample Size
100mm*40mm

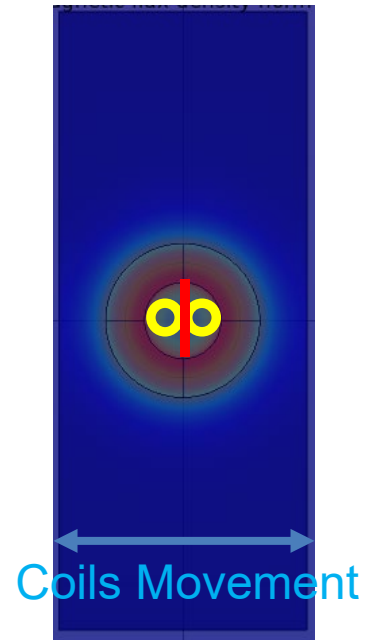

Current Density Distribution (XY)

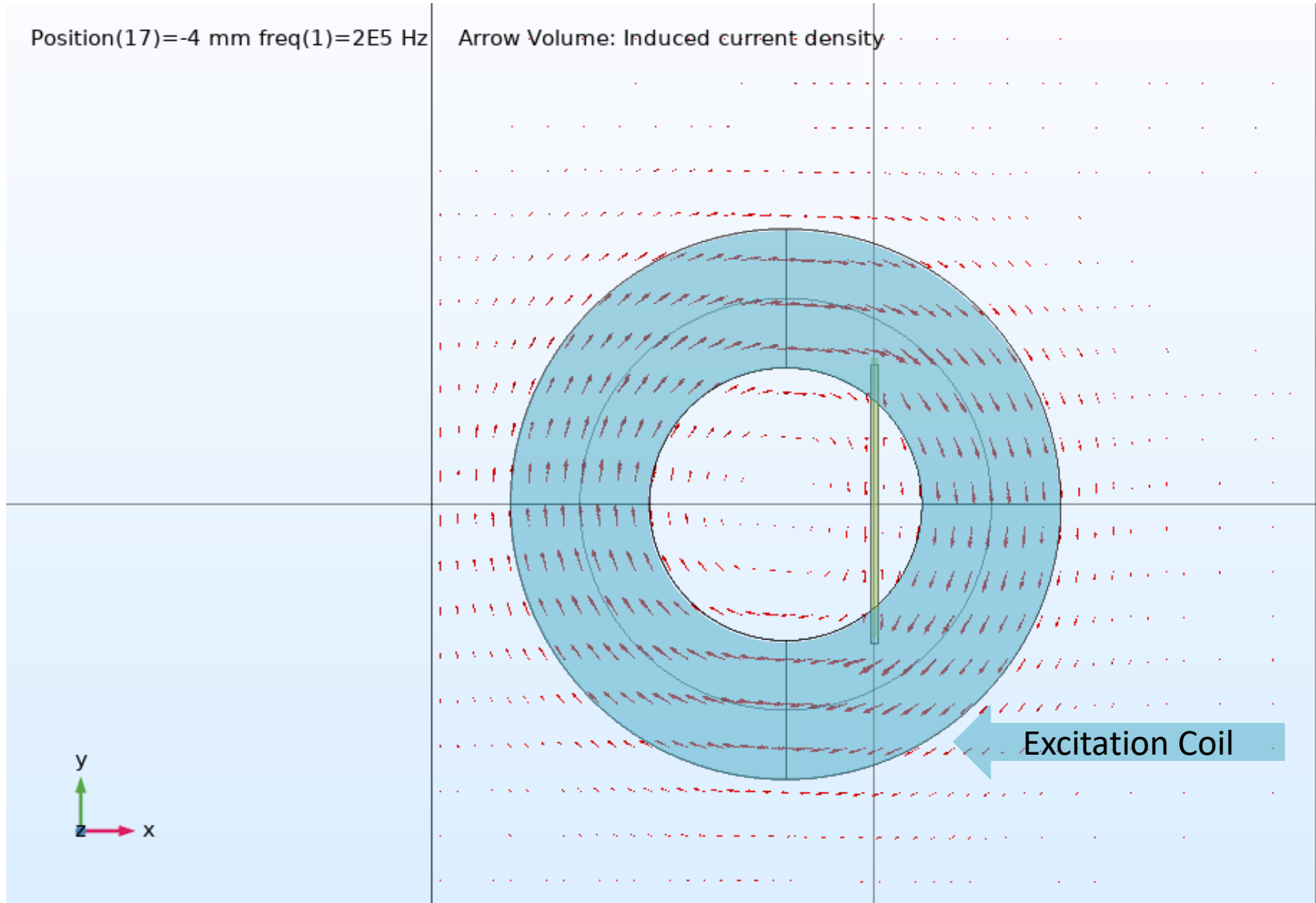

Current Density Distribution (YZ)

Position(17)=-4 mm freq(1)=2E5 Hz Arrow Volume: Induced current density

Skin Depth: current density has fallen to $1/e$ (about 0.37) of J_s

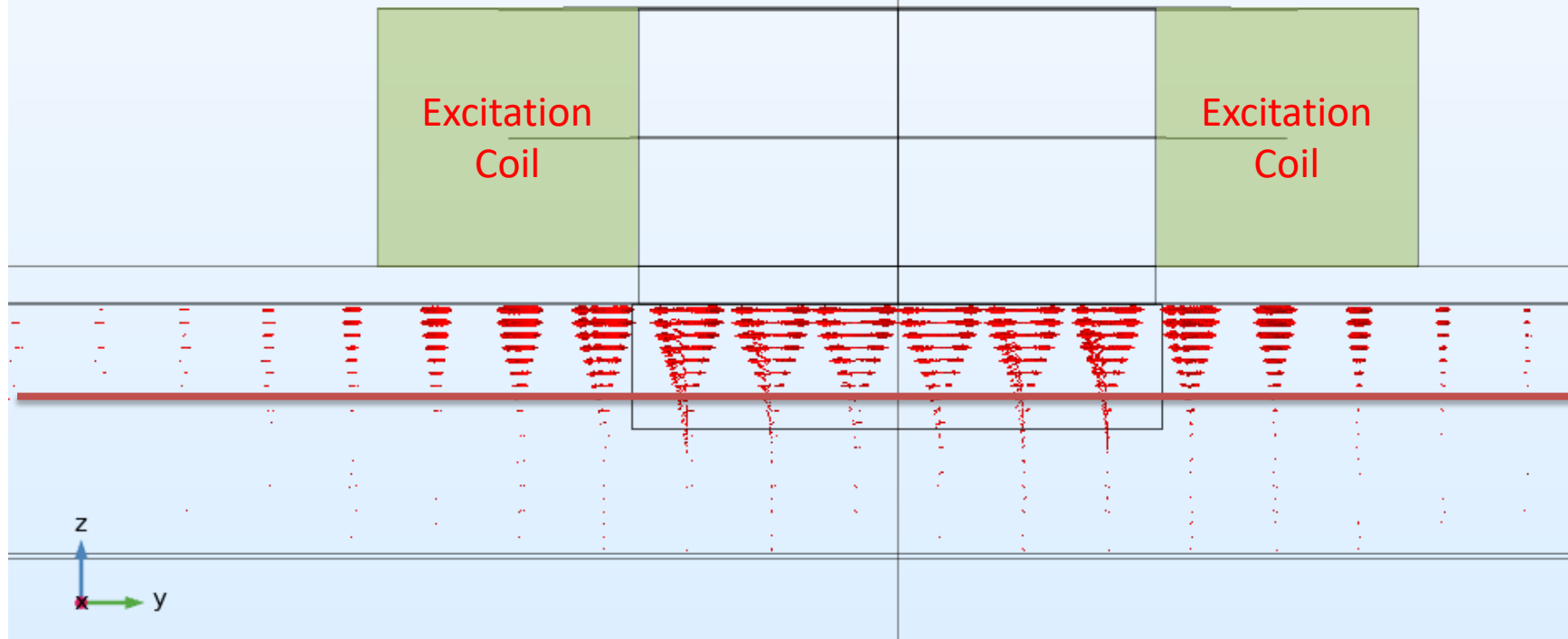

Skin Depth ~ 2mm (Total Sample Thickness 6mm)



Current Density Distribution (XZ)

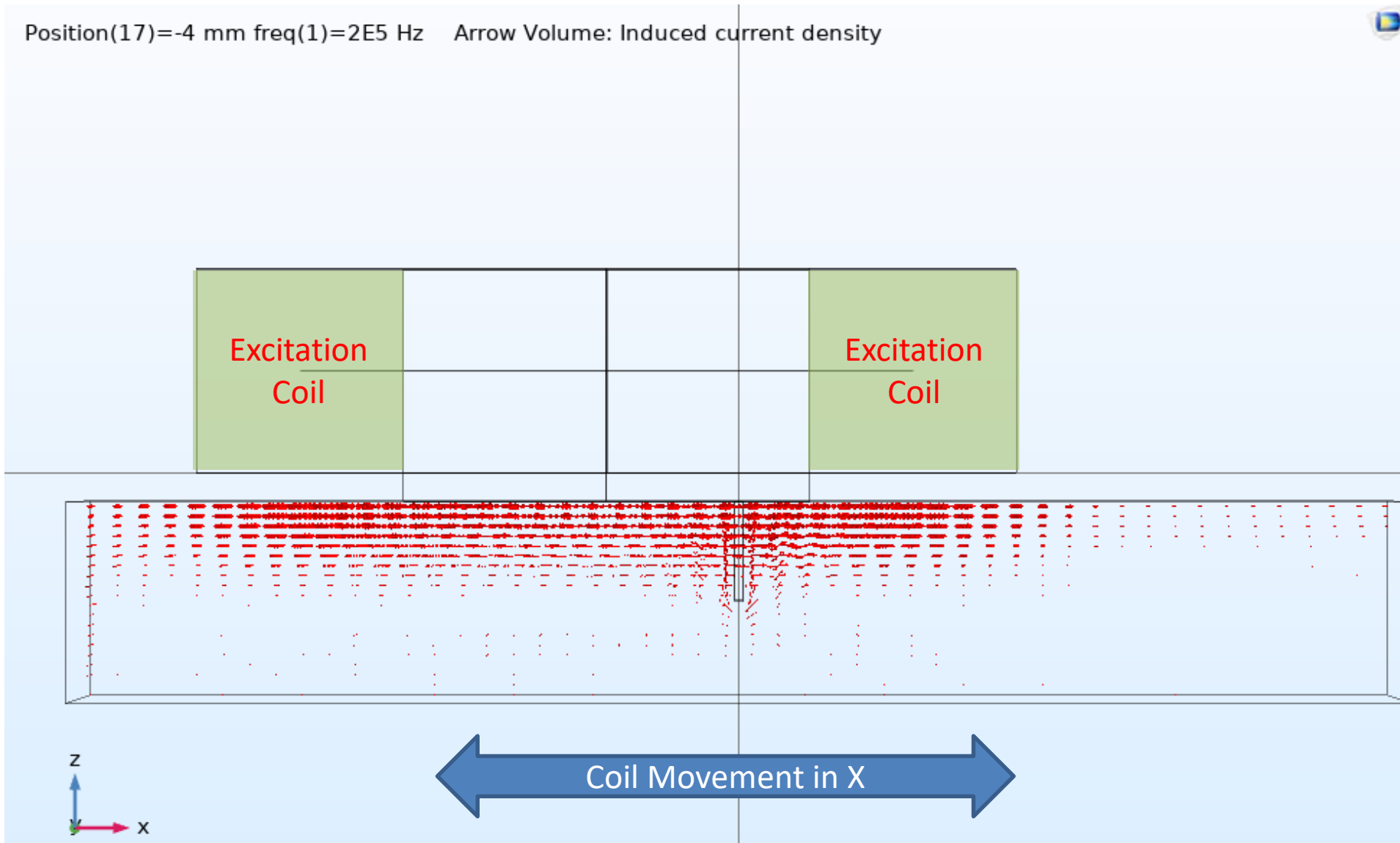

MAPPER + EDDY-CURRENT PROBE

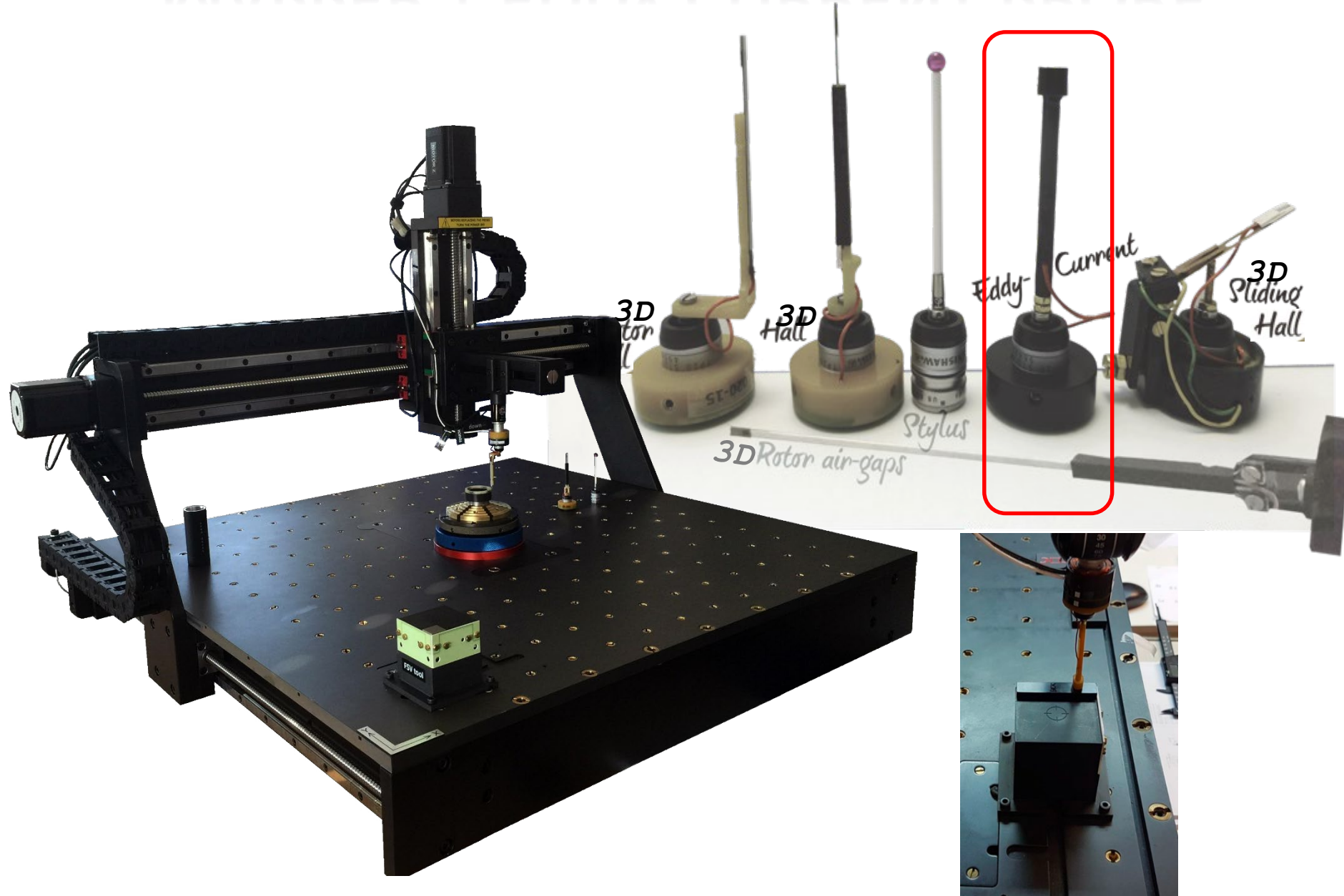

SENIS EDDY-CURRENT PROBES

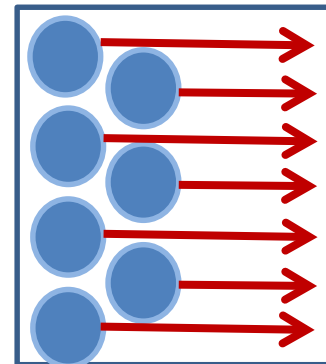
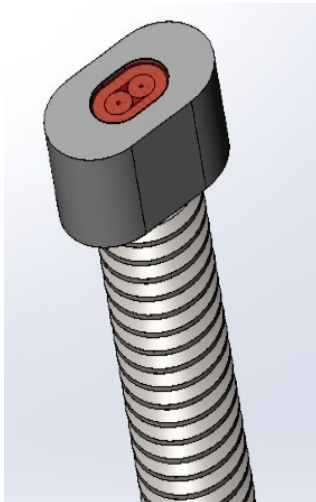
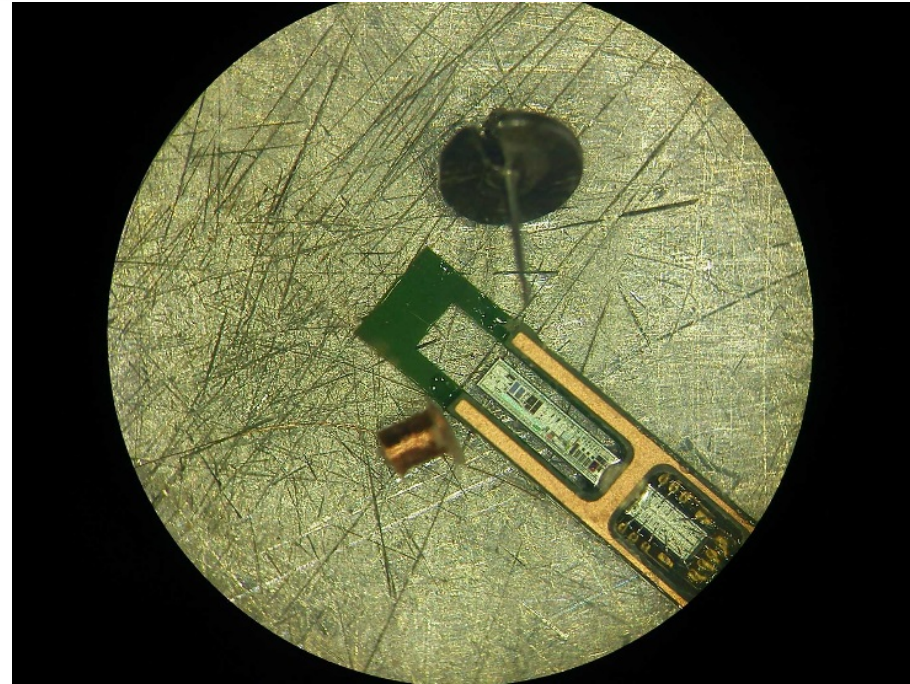
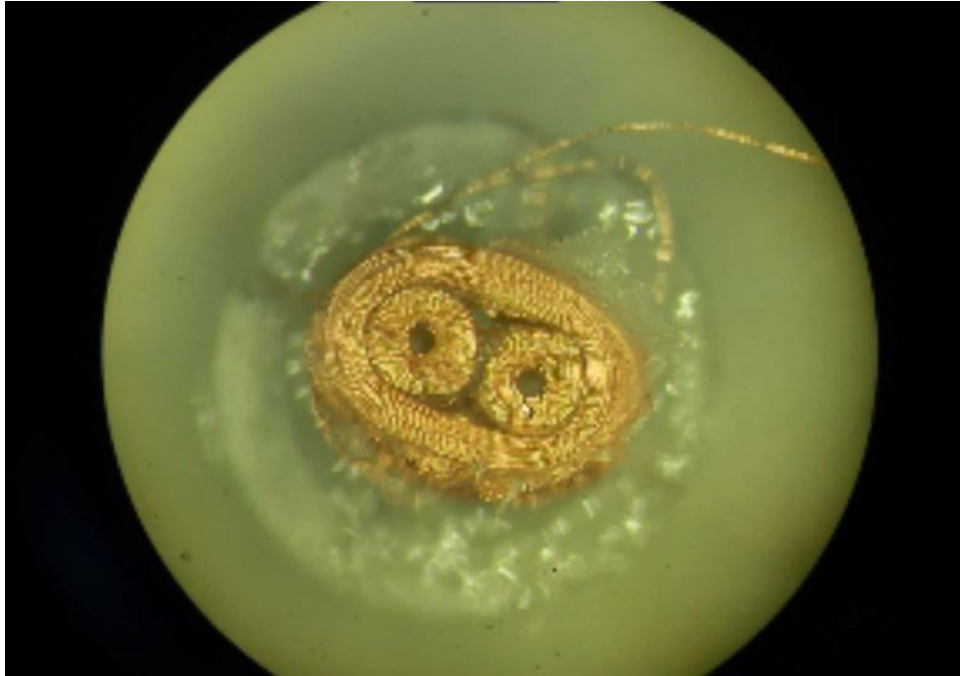

NEW PROJECT REQUIREMENTS

- Non-magnetised and epoxy coated magnet blanks of different sizes need to be separated from each other and put on the linear transport system
- Only the edge part of magnet need to be measured (6mm area on all four edges from both sides of the magnet blanks, i.e. length and width)
- The magnet thickness will be measured to adjust the distance (air-gap) between magnets and eddy current probe arrays
- An operator interface software for entering the magnet and test data, such as Article, Date, Op. Name, Lot number...
- GOOD / BAD decision will be made based on a SENIS proprietary algorithm for crack detection
- A calibration software using 5 golden parts to periodical compensate offset
- 100% in-line production test – test duration: <7sec per magnet

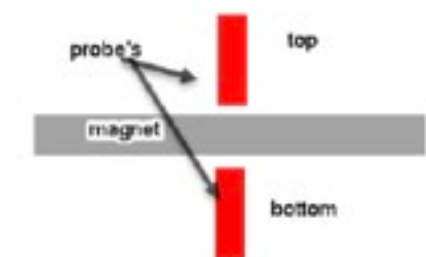
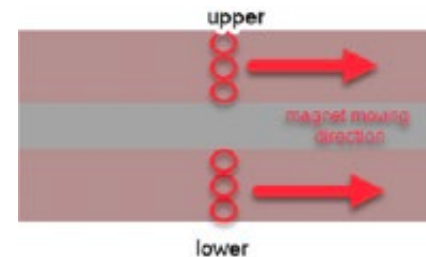
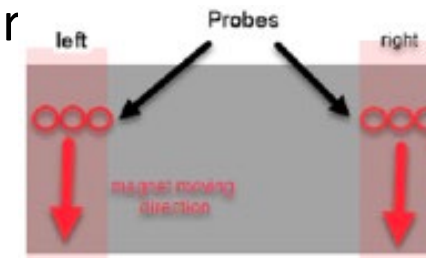
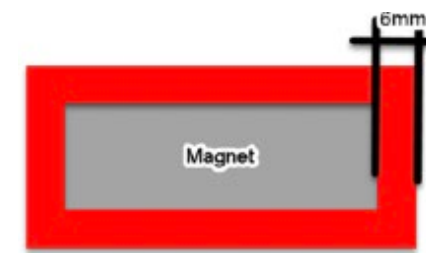

PARTS FLOW

optical position sensors detect the magnet on the transportation system with encoders

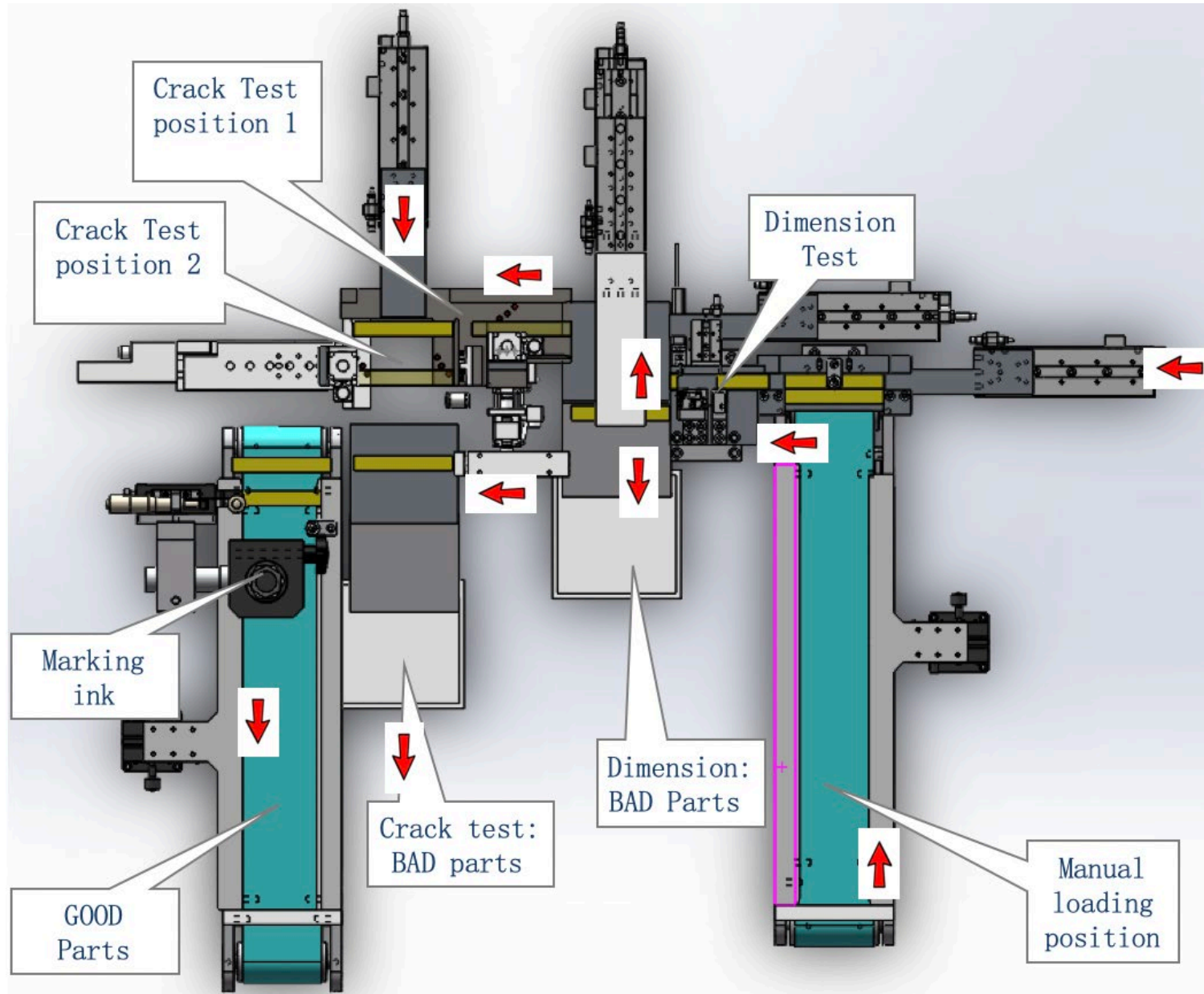

IMPLEMENTATION

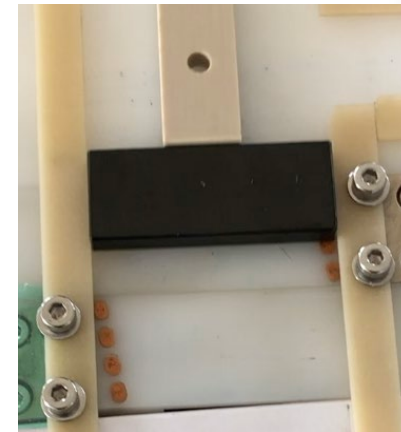
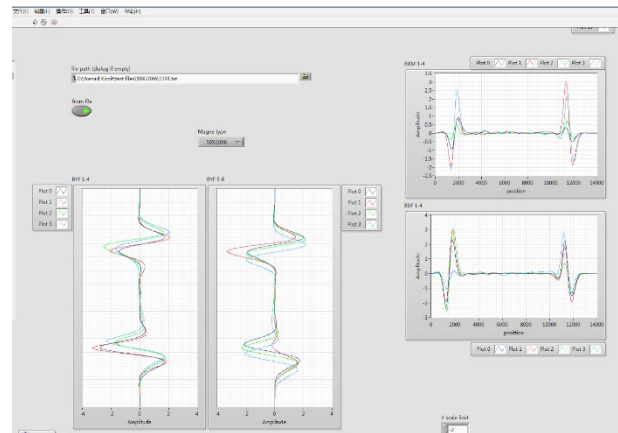
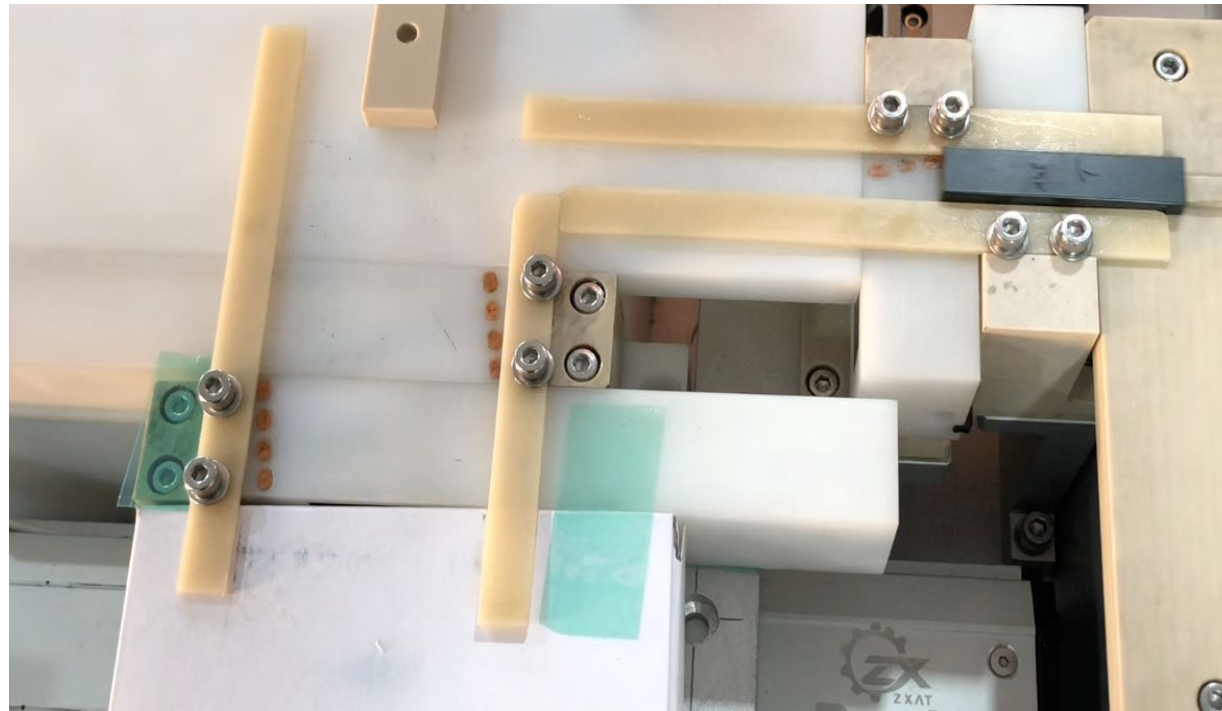

RESULT – CRACK DETECTION

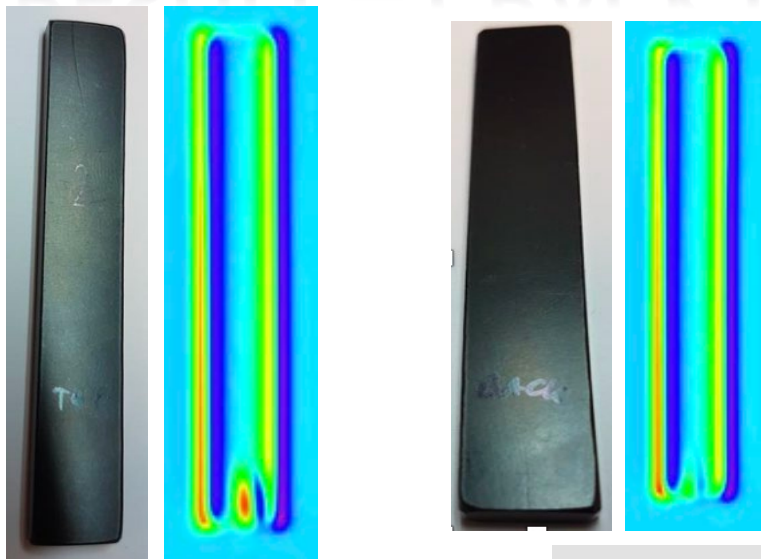

- The contrast reflects the voltage difference between two coils.
- Compared with cracks, magnet edges shows higher color contrast.

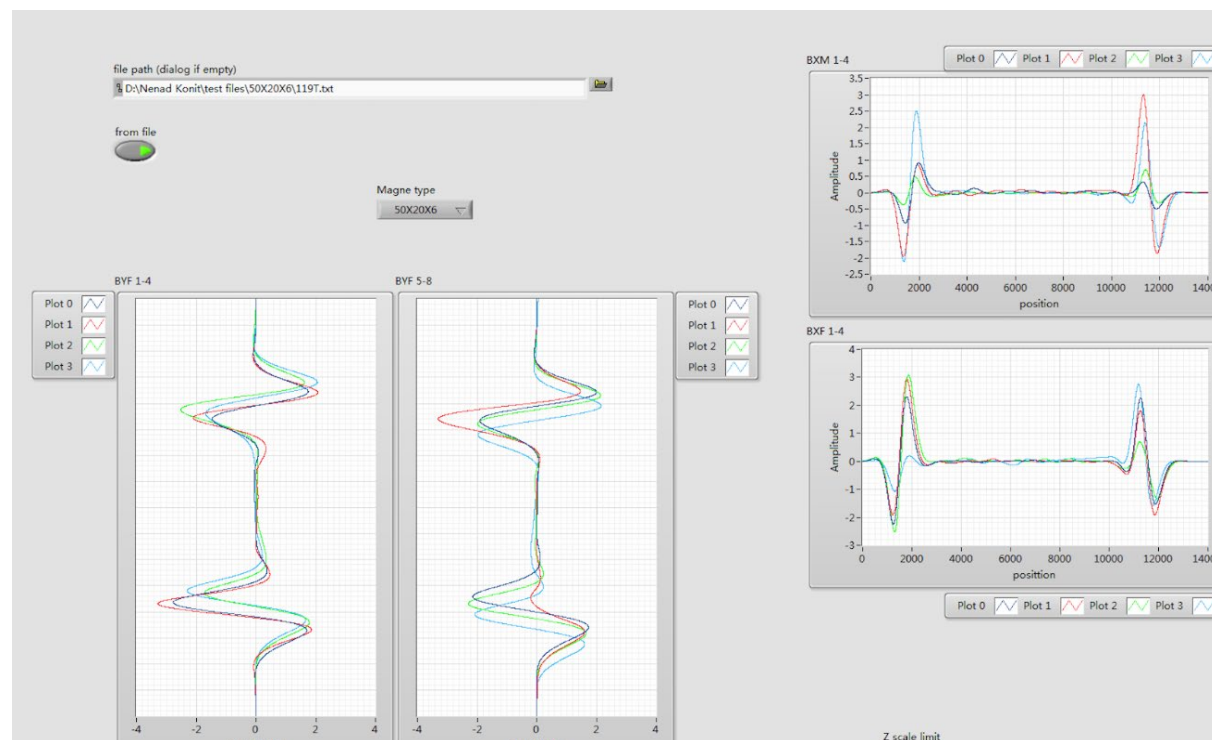
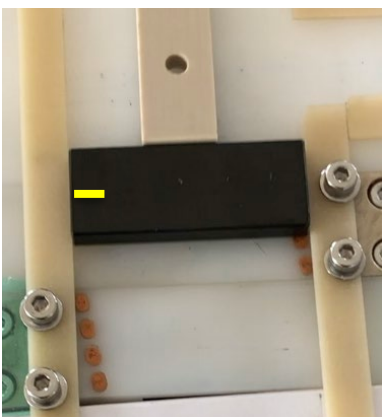

Website

Senis: <http://www.senis.ch/>

GMW Associates: <https://gmw.com/>

Email:

Sasa Spasic: spasic@senis.ch

Zhen Xu: zhen.xu@gmw.com

