

*Operation Manual for
Mag-01H Fluxgate Declinometer/Inclinometer
with non-magnetic Wild T1 Theodolite*



THIS PAGE BLANK

Table of Contents

1. About this Manual	5
1.1. Symbols Glossary	5
2. Safe Use	5
3. Introduction	6
3.1. The Null Method of Measurement	7
3.2. Resolution	7
4. The Magnetometer	9
4.1. Magnetometer Operation and Controls	9
4.2. The Probe	9
4.3. Electromagnetic Compatibility	10
5. The Theodolite	11
5.1. Night Viewing	13
5.2. Steep Sighting Prisms	13
5.3. Objective Sun and Orange Filters	13
6. Taking Measurements	14
6.1. Magnetic Hygiene	16
6.2. Theodolite Set-up	16
6.2.1. Levelling the Theodolite	16
6.2.2. Setting Over A Reference Point (Tripod Mounted)	17
6.2.3. Setting Over A Reference Point (Pillar Mounted)	17
6.3. Performing Observations of D&I with A Non-Resettable Horizontal Circle Theodolite	18
6.4. Taking Readings	18
6.5. Performing Observation of Declination	19
6.6. Performing Observation of Inclination	21
7. Repair and Maintenance	22
7.1. Checking the System	22

BARTINGTON INSTRUMENTS

7.1.1. Battery Check	22
7.1.2. Functional Check	22
7.1.3. Theodolite Optical Check	22
7.2. Calibration	23
7.3. Probe Cable Repairs	23
7.3.1. Replacing the cable	25
7.3.2. Probe Electrical Resistance Values	25
7.4. Mag-01H Battery Replacement	25
7.5. Probe Alignment	26
7.5.1. Method	26
7.6. Offset Trimming	27
7.7. Cleaning the D/I System	27
8. Storage and Transport	28
9. End of Life Disposal	28
9.1. Waste Electrical and Electronic Equipment (WEEE) Regulations	29
Appendix 1: Observatory D/I Record Sheet	30
Appendix 2: Example International Geomagnetic Reference Field	31

1. About this Manual

This document describes the installation, operation and maintenance of the Mag-01H Fluxgate Declinometer/Inclinometer (D/I) System. It should be read in conjunction with:

- the [product brochure](#) DS0070
- [operation manual](#) OM0382, which describes the operation of the Mag-01H magnetometer
- the WildT1 theodolite [operation manual](#).
- the [training video](#) for the use of the Mag-01H Fluxgate D/I System.

All are available on the Bartington Instruments website at www.bartington.com.

1.1. Symbols Glossary

The following symbols used within this manual call your attention to specific types of information:



WARNING: Indicates a situation in which serious bodily injury or death could result if the warning is ignored.



Caution: Indicates a situation in which bodily injury or damage to your instrument, or both, could result if the caution is ignored.



Identifies items that must be disposed of safely to prevent unnecessary damage to the environment.

Note: A note provides useful supporting information and sometimes suggests how to make better use of your purchase.

2. Safe Use



WARNING: The Mag-01H is powered by mains electricity and contains uninsulated parts. Ensure that the unit is properly earthed at all times. Only properly trained personnel should carry out procedures in this manual which require the casing to be opened.



WARNING: These products are not qualified for use in explosive atmospheres or life support systems. Consult Bartington Instruments for advice.

3. Introduction

The Mag-01H Declinometer/Inclinometer (D/I) System comprises a high sensitivity, battery powered, magnetometer type Mag-01H together with a vector sensing fluxgate Mag A probe which is mounted on a Wild T1 non-magnetic theodolite.

The system permits very precise angular measurements of the terrestrial magnetic field F . The angular components measured are Declination D and Inclination I .

- Declination is the azimuth angle between the Geographical Meridian GM and the Magnetic Meridian MM .
- Inclination is the vertical angle between F and the horizontal measured in the direction of the Magnetic Meridian.

The value of F , together with the components X (MM horizontal), Y and Z (vertical) may also be measured to an accuracy of 0.25%.

The system is suitable for permanent installation on a non-magnetic pillar in observatories, using a pillar mounting plate. The provision of a non-magnetic tripod and the re-chargeable batteries within the magnetometer also permit mobile observatory use, enabling highly detailed mapping of D and I .

See [Taking Measurements](#) for further details of taking measurements.

The system is used in observatories to obtain reference data which may be used in the construction of Reference Field Charts. See [Appendix 2](#) for an example of an International Geomagnetic Reference Field (IGRF) chart.

Note: The Earth's magnetic field is constantly changing. Current IGRF charts are available from organisations such as the British Geological Survey (BGS) (www.geomag.bgs.ac.uk/).

Other applications include checking of compasses and monitoring of the field for compass correction purposes, or in-field referencing in directional drilling operations. Detailed knowledge of local variation in D and I may be of assistance in interpreting total field magnetometer survey data.

The ultimate resolution achieved with this system is limited by four factors:

- 1. Prevailing magnetic conditions.** Measurements during magnetic storms can be extremely difficult to perform.
- 2. The degree of arc required.** The Wild T1 theodolite has a resolution of 6 seconds of arc, with estimates possible to 2 seconds.
- 3. Plinth stability.** The tripod is less stable with time and temperature than a stone pillar.

- 4. The noise level, and therefore resolution, of the magnetometer.** Two sensitivity settings are provided: x1, which produces a resolution of 1nT, and x10, which produces a resolution of 0.1nT. The x10 sensitivity setting would normally only be used under ideal conditions.

Note: The system is usually operated with the assigned magnetometer and theodolite combination specified in the test documentation. Should a replacement magnetometer be used, offset errors up to 5nT may be encountered. The accuracy of the system will not be compromised provided that the four-measurement method described in this manual is used.

3.1. The Null Method of Measurement

Measurements are obtained by operating the probe mounted on the theodolite in the null mode. In this mode observations are performed with the probe orientated perpendicular to the direction of the terrestrial magnetic field F . At an angle of 90° to the field the response of the probe produces the greatest sensitivity to small changes in the field direction.

Note: Ultimate accuracy will depend on the prevailing magnetic conditions. The high flexibility cable connecting the probe to the magnetometer does not interfere with the measurement procedure and will operate down to very low temperatures.

Note: The use of low magnetic signature components within the Mag-01H instrument enables this unit to be used close to the probe head. Errors will not be significant with the probe and magnetometer as close as 0.5 metres, although the magnetometer is, in practice, usually placed on the ground.

Variation in either D or I is indicated by d . Variation in Declination (dD) or Inclination (dI) around a fixed null point can be continuously monitored via the analogue output. For small angular changes, the relationship between magnetometer output and angle will be linear.

3.2. Resolution

The theoretical resolution R to small changes in field direction is proportional to the resolution of the magnetometer and the strength of the perpendicular magnetic field. When measuring Inclination, the magnetic axis of the probe is parallel to the vertical plane of investigation. Therefore the full field strength F is available and the resolution becomes $R_{dI} = F \sin dI$.

When measuring Declination the magnetic axis of the probe is parallel to the horizontal plane of investigation. As a result, only the horizontal field component $H = F \cos I$ is available. Therefore, for Declination measurements, the resolution becomes $R_{dD} = H \sin dD$.

Note: At any magnetometer resolution, resolution of Inclination I is dependent on the magnitude of F alone, whereas resolution of Declination D is dependent on H and I and will generally vary with latitude.

Example (where $F = 47,000\text{nT}$, $I = 67^\circ$):

On x1 sensitivity (1nT): Rdl = circa 5 seconds RdD = circa 10 seconds

On x10 sensitivity (0.1nT): Rdl = circa 0.5 seconds RdD = circa 1.0 seconds

Note: These are theoretical values and actual values will be determined by prevailing conditions.

From the IGRF chart in [Appendix 2](#) it can be seen that resolution in Declination is at a minimum at the poles and at a maximum at the equator.

4. The Magnetometer

4.1. Magnetometer Operation and Controls

See [operation manual OM0382](#) for a description of the Mag-01H's operation, and a description of the front and rear panel controls.

4.2. The Probe

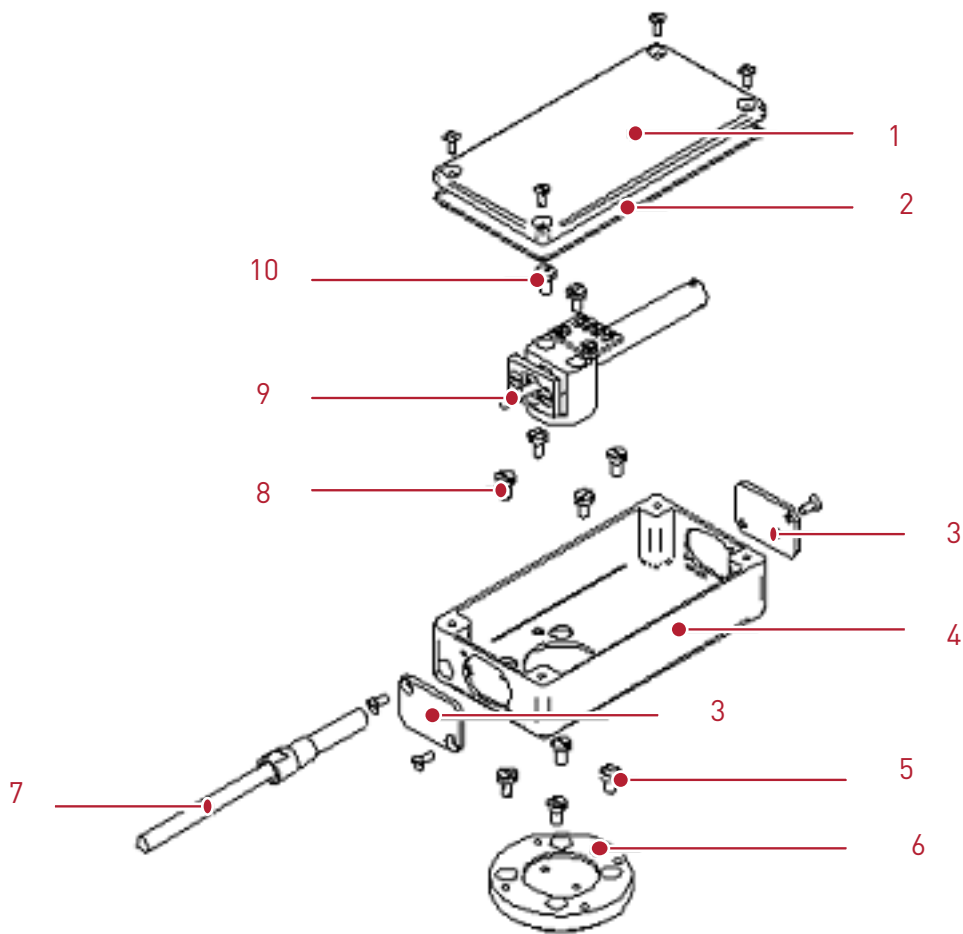

Figure 1. Theodolite mounted Mag A probe assembly.

Key to Figure 1

- | | |
|--------------------------|------------------------------|
| 1. Enclosure lid | 6. Mounting plate |
| 2. Enclosure gasket | 7. 5m cable to magnetometer |
| 3. Blanking plates | 8. Enclosure mounting screws |
| 4. Enclosure | 9. Fluxgate Mag A probe |
| 5. Mounting plate screws | 10. Probe mounting screws |

The probe consists of a precision fluxgate magnetic field sensor mounted within a tube. A joystick arrangement for trimming the alignment of the sensor relative to the tube is provided. The probe is mounted on a pillar enclosed in a rugged housing, which fully protects it against mechanical damage or potential misalignment. The probe and enclosure are individually

attached to a mounting plate, which is retained by four screws to the theodolite telescope. Gasket sealing is provided to prevent the ingress of moisture.

The instrument is supplied with the probe aligned parallel to the optical axis of the theodolite to within 10 seconds of arc.

A high flexibility cable connects the probe to the electronics unit. If the cable is not already fitted to the cover, follow the instructions for fitting in [Probe Cable Repairs](#) below.

4.3. Electromagnetic Compatibility

The Mag-01H instrument contains no high frequency electronics likely to cause emissions which could affect other apparatus. The design, including the use of a rechargeable battery (charged from a mains adaptor) and the decoupling of internal power supplies, is intended to produce minimal emissions. Other equipment operating in the area is therefore unlikely to be affected.

Note: The unit itself is also unlikely to be affected by interference from other equipment in the normal operating environment. However, the probe is designed to measure magnetic fields and therefore is susceptible to electromagnetic interference. Operation close to a high frequency source of radiation should be avoided. Interference is indicated by instability in the reading when the probe is maintained in a fixed position.

5. The Theodolite

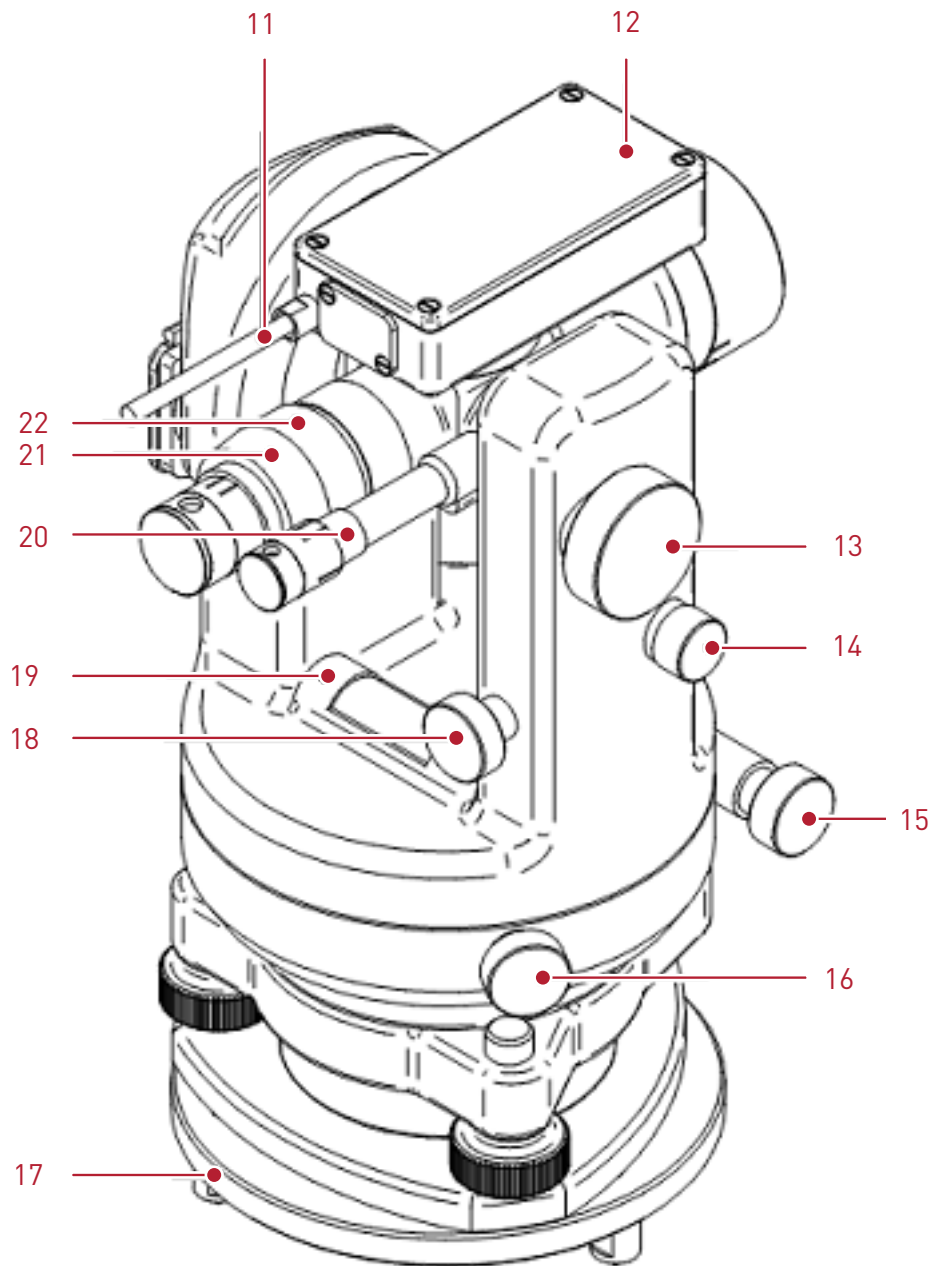

Figure 2. Non-magnetic Wild T1 theodolite key operational features, view 1.

Key to Figure 2

- | | |
|--|-----------------------------------|
| 11. High flexibility cable to magnetometer | 17. Pillar mount adaptor (Trivet) |
| 12. Probe | 18. Vertical circle adjustment |
| 13. Micrometer | 19. Tubular level |
| 14. Vertical circle clamp | 20. Scale focusing ring |
| 15. Horizontal circle adjustment | 21. Graticule focusing ring |
| 16. Horizontal circle clamp | 22. Telescope focusing ring |

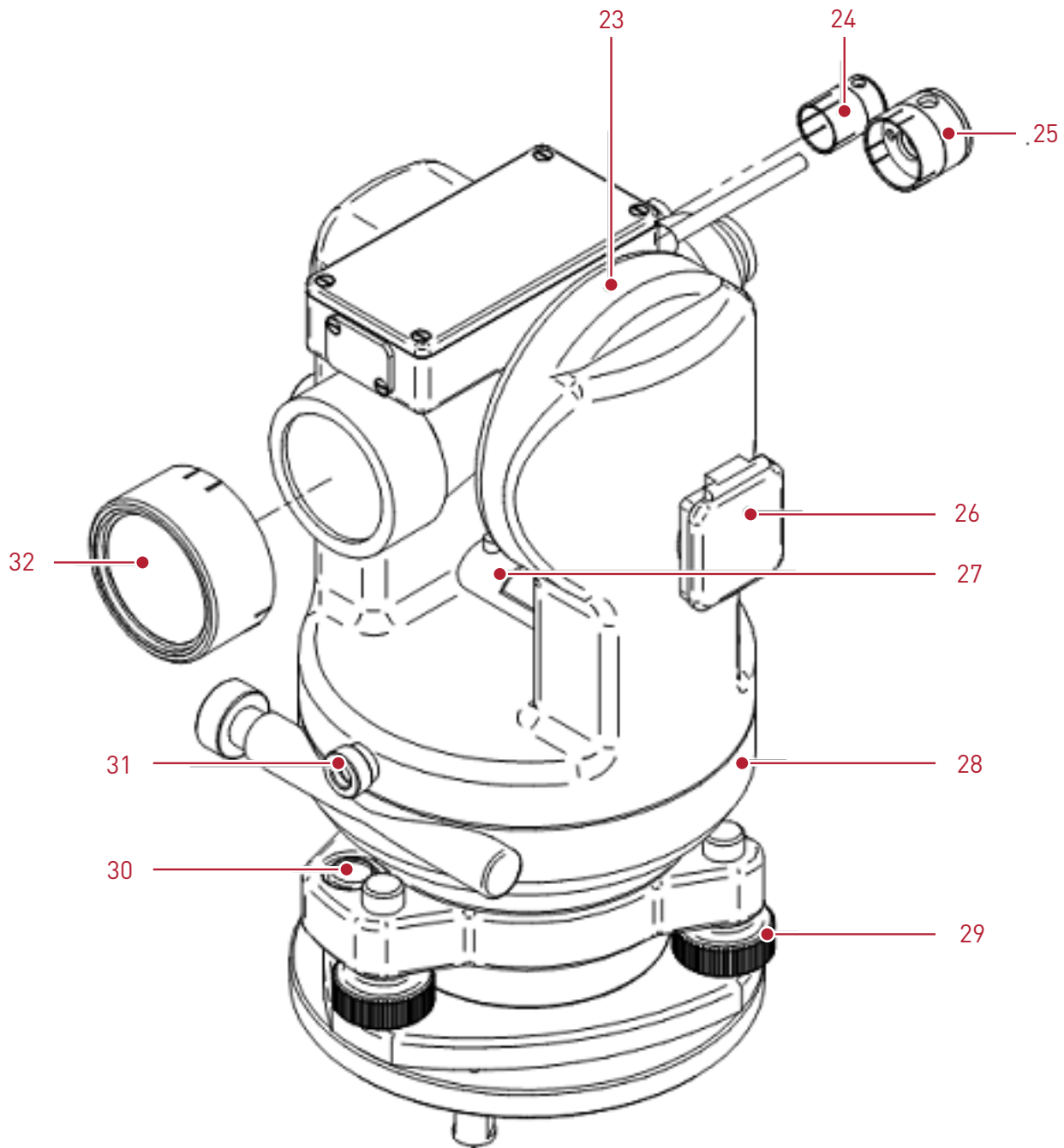

Figure 3. Non-magnetic Wild T1 theodolite key operational features, view 2.

Key to Figure 3

- | | |
|---|-------------------------------|
| 23. Vertical circle housing | 28. Horizontal circle housing |
| 24. Steep sighting prism (Scale: non-inverting) | 29. Levelling screws |
| 25. Steep sighting prism (Tekescope) | 30. Circular level |
| 26. Scale illuminator mirror | 31. Optical plumb |
| 27. Tubular level adjuster | 32. Solar or orange filter |

The Wild T1 is a 6-second accuracy, non-magnetic theodolite. The accuracy stated is for the mean square of a single Circle Left (CL) measurement and a single Circle Right (CR)

measurement. (Circle Left and Circle Right refer to the position of the vertical circle housing relative to the observer: See [Performing Observation of Declination](#).)

The theodolite undergoes a rigorous magnetic hygiene inspection at Bartington Instruments prior to fitting the probe. Any contamination is totally removed to guarantee complete magnetic cleanliness. Optical and magnetic calibrations are also carried out prior to despatch.

5.1. Night Viewing

The scale illumination lamp unit supplied by Wild is unsuitable due to its magnetic signature. The alternative, recommended and supplied by Bartington, is a chemiluminescent light stick. These are approximately 47mm length x circa 6 mm diameter. Bend the light stick to activate it and place between the theodolite mirror and window to provide illumination.

Note: Night adjusted vision responds to this level of illumination, but below freezing point the illumination may become inadequate.

5.2. Steep Sighting Prisms

When performing steep angled telescopic observations or attempting to perform null mode magnetic measurements for shallow angles of I , a pair of steep sighting prisms will be required. These will extend the vertical-viewing angle from circa 40° to 18° .

There are two types of prism. The larger type fits the telescope eyepiece and results in an inverted image. The smaller prism fits the scale eyepiece and results in a non-inverted image.

5.3. Objective Sun and Orange Filters

The orange filter can be used to eliminate glare, for example, when viewing a target.

Check frequently that the filter is reliably fitted to the telescope objective lens during observations.



WARNING: Failure to check, fit and use the sun filter when performing solar observations may cause irreparable damage to the user's eyes. Bartington Instruments can accept NO liability for injuries resulting from solar observations, as we have no control over the circumstances of use.

Note: The sun filter must be fitted when performing solar observations. It provides an attenuation of above 1/100,000. Inspect the filter to ensure the free-floating silver membrane is present and undamaged prior to use.

6. Taking Measurements

This section describes the procedures for measurement of Declination and Inclination in the null mode. Four readings are obtained for calculation of D and four readings are obtained for calculation of I. Each set of four comprises two pairs of readings. One pair is averaged to eliminate electronic offset errors and the other pair is averaged to eliminate mechanical alignment errors (probe collimation).

Figure 4 describes the conventions in making observations for identifying the directions of observation when performing null mode measurements. Figures 5 and 6 give further details of the null mode of measurements.

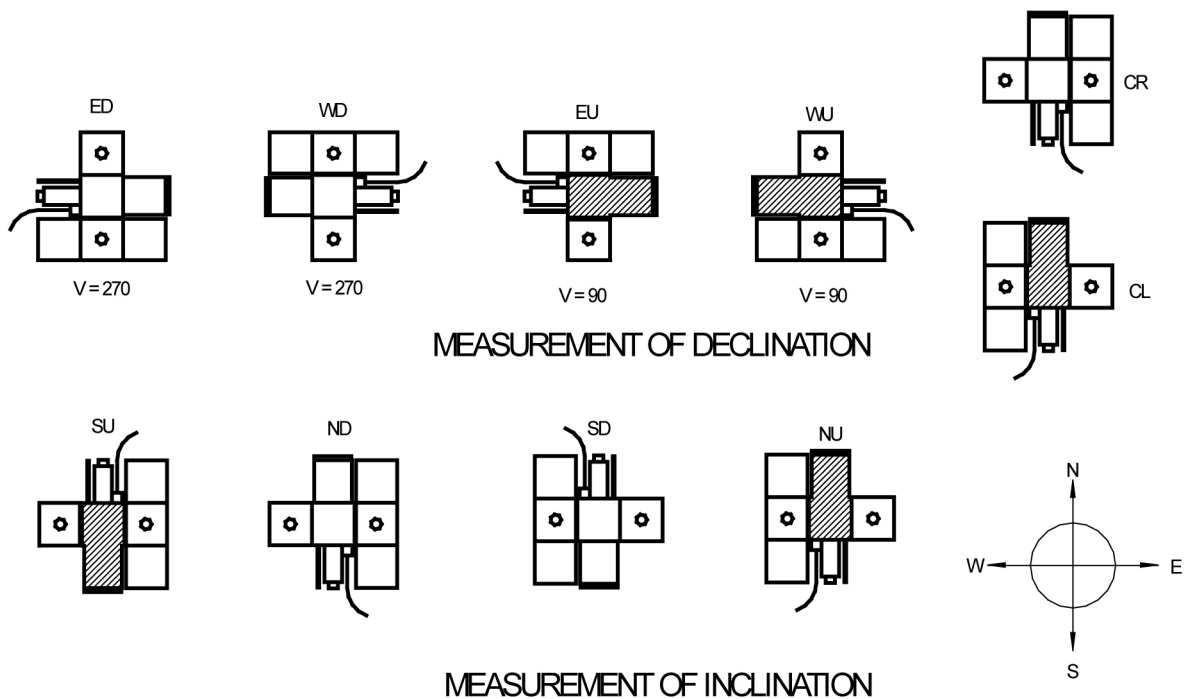

Figure 4. Plan view of observation positions for D & I

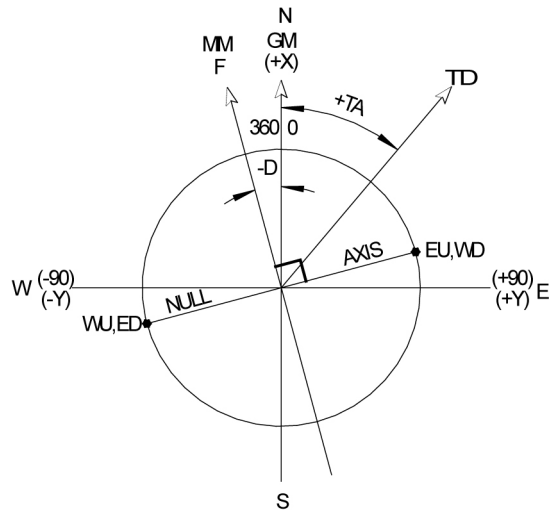

Figure 5. Observations of Declination in the horizontal circle.

Key to Figure 5

- D. Angle of declination D (variation) is the azimuth angle between the geographical meridian GM and the magnetic meridian MM.
- F. The direction of the terrestrial field.
- TD. Reference target datum.

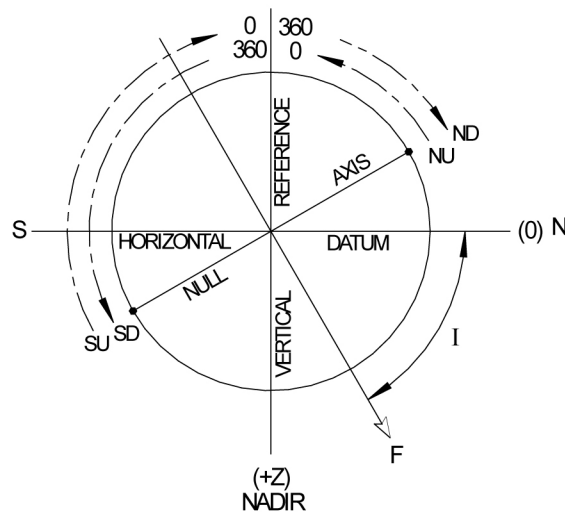

Figure 6. Observations of Inclination in the vertical circle.

Key to Figure 6

- I. Angle of inclination I (DIP) is the vertical angle of the terrestrial field F relative to the horizontal plane. The plane of the vertical circle is set parallel to the magnetic meridian MM.
- O. The horizontal datum (0) is determined by the pendulum compensated vertical reference (+Z).

In Figures 5 and 6, E, W, N and S refer to the direction in which the telescope is pointed, while U and D refer to the position of the probe with respect to the telescope: Up (above the telescope) and Down (below the telescope). Thus for example ED is East Down; NU is North Up etc.

Declination is calculated from the mean of the four observations ED, WD, EU, WU. The reference observation for Declination is the Geographical Meridian (GM) obtained using a Circle Left / Circle Right observation to eliminate optical collimation errors.

The azimuth reference for Declination may be surveyed relative to the reference position of the theodolite.

Declination must be discovered before Inclination can be measured. Inclination is calculated from the mean of the four observations SU, ND, SD, NU with the telescope aligned with the calculated Magnetic Meridian. The reference observation for Inclination is the horizontal plane, which is automatically derived from the fluid filled gravity compensator in the vertical reference within the theodolite. Observations are made on the vertical circle, the plane of which must be parallel to the Magnetic Meridian.

It is customary to record the time in Universal Time (U.T.) at which each of the eight measurements is recorded. The mean time for D and for I can then be calculated subsequently for record purposes.

6.1. Magnetic Hygiene

Note: Before attempting magnetic observations, ensure adequate personal magnetic hygiene. For example, garments should be free from steel fasteners or buckles.

Magnetic hygiene can be checked when commencing observations by moving hands, head and torso close to the probe and observing any change in reading. Readings should not vary by more than 0.2nT. In practice only the hand used for circle slow motion adjustment will be close to the probe at critical times during measurement. Ultimate accuracy will depend on ambient magnetic noise. The diurnal variation of the terrestrial field becomes most active at dawn and dusk.

6.2. Theodolite Set-up

For reference, see [Figure 2](#) and [Figure 3](#), and the [WildT1 theodolite manual](#).

Note: When moving to a new site, allow at least 1 minute per 1K of temperature difference to allow the theodolite to reach the ambient temperature.

To avoid ambiguous values for the magnetic meridian, place the theodolite on the pillar or tripod such that the 0/360° horizontal circle transition will be clear of the four declination null point readings.

6.2.1. Levelling the Theodolite

(See also the [WildT1 theodolite manual](#).)

1. Use the three foot-screws to level the theodolite base using the circular level.

2. Rotate the telescope to a horizontal position with the probe at the top and apply the vertical clamp. Release the horizontal clamp and align the tubular level between any two foot-screws A and B. Foot screws A and B should be turned in opposite directions by equal amounts until the tubular level is centred.
3. Rotate the Theodolite clockwise by 90 degrees to align the tubular level with the third foot-screw C, and adjust the level in that direction using foot-screw C. Rotate 180 degrees and reduce any error by half, again using foot-screw C.
4. Rotate theodolite by 90 degrees clockwise. Note the position of the tubular level bubble. Bring the bubble to a halfway position between this position and a centred position by turning foot screws A and B by equal and opposite rotations.
5. Rotate theodolite by 90 degrees clockwise. Turning foot screw C bring the bubble to its mean (halfway position).
6. Check that the bubble now remains in its mean position through full rotation.
7. Repeat the above steps as necessary, centring on the mean position until it remains stable.

6.2.2. Setting Over A Reference Point (Tripod Mounted)

1. Position the tripod (if used) over the ground reference point with its head level. Mount the theodolite and level the instrument using the circular plate level and foot-screws.
2. To focus the optical plummet (tripod only) on the graticule, turn the eyepiece and focus on the ground point by pulling or pushing the eyepiece tube. Line up the graticule and target point by adjusting the tripod legs and/or instrument foot-screws as necessary.
3. Re-level the instrument with the foot-screws and complete fine centring by moving the instrument on the tripod head. If necessary, repeat levelling and centring procedure until instrument is level, directly over the ground point.

6.2.3. Setting Over A Reference Point (Pillar Mounted)

When siting the theodolite on a pillar, the procedure is similar to that in the previous; however, when pillar mounted, the optical plummet would not be used and the pillar mounting plate would be fitted to the theodolite.

Use the tubular plate level to level the theodolite to better than $\pm 15''$. Each 2mm interval represents 30'' error. If this cannot be achieved then there is a problem in the setting of the tubular level. This error can be completely eliminated using an adjuster pin as follows.

1. Attempt to level with tubular level set in line with a pair of levelling screws.
2. Rotate to the next pair of levelling screws. Remove half the error using the tubular level adjuster and half the error using both the level adjustment screws.

3. Rotate to the next pair of levelling screws and repeat the adjustment.
4. Rotate and continue adjustment until the desired accuracy is achieved.

6.3. Performing Observations of D&I with A Non-Resettable Horizontal Circle Theodolite

The re-settable circle previously provided on the steel equivalent theodolite is not required for accurate measurement of D and I and has been eliminated. The likelihood of incorrect circle settings is reduced and the best observation method is adopted.

Note: A digital calculator will be required which can convert degrees, minutes and seconds to decimal values and vice-versa. Alternatively, computer programs are available to assist with data reduction.

An accurate digital clock with a large display positioned away from the theodolite is also required.

The observation conventions are described pictorially in Figures 4, 5 and 6.

Two optical and four magnetic measurements are performed for each observation, and the results are averaged to eliminate system optical and magnetic errors. Worked examples are given at the end of this section. The examples are for explanation only and do not show the system errors.

6.4. Taking Readings

Note: After levelling the theodolite, the vertical and horizontal scales will be in a random position.

1. Direct the theodolite at the reference target or a null field position. After aligning in the direction of interest the circle graduation lines are unlikely to be exactly in the middle of the double line index, and will more likely resemble those displayed in Figure 7, below.
- 2.

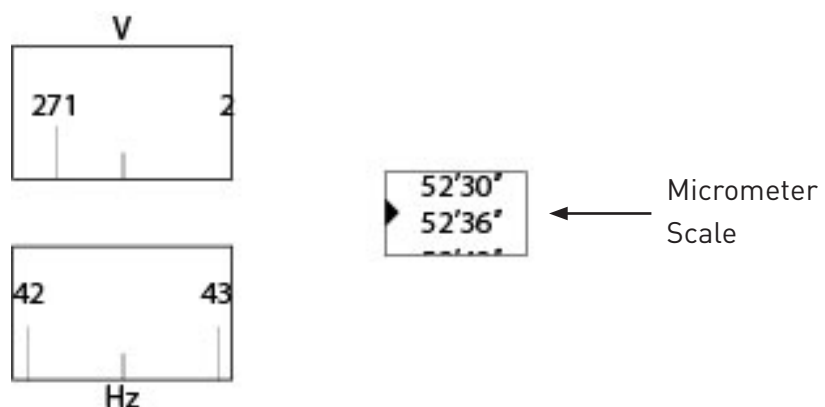

Figure 7 Example of likely position of circle graduation lines.

3. To achieve a correct reading, turn the micrometer screw to align the circle graduation line exactly in the middle of the double line index (see Figure 8 below).

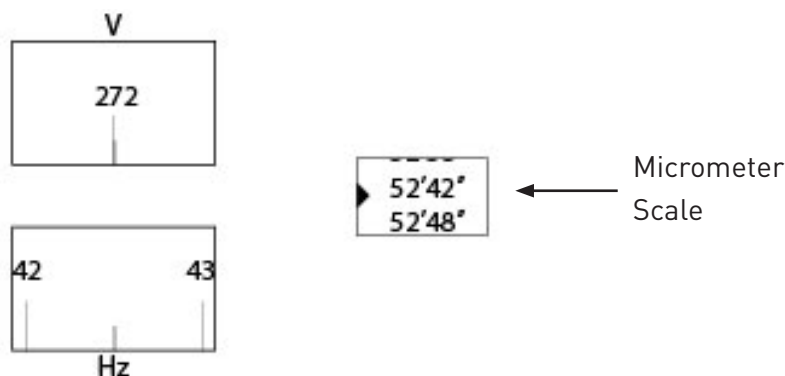

Figure 8. Circle graduation line aligned exactly in middle of double line index.

4. **Example:** The vertical measurement displayed in Figure 8 is approximately $272^{\circ}52'44''$.

Note: For further information refer to the [Wild T1 manual](#), section 4.5.

6.5. Performing Observation of Declination

Connect the probe cable to the magnetometer and switch on the instrument. Prior to commencing measurements, decide which sensitivity setting can be used. Attempt a trial null measurement on x10 sensitivity (0.1nT resolution). If noise exceeds 0.5nT p-p then x1 sensitivity setting should be used. This is recommended for most observations.

Note: Before taking readings on the Mag-01H, ensure that the offset control is set to zero and the toggle switch is in a central position.

Note: A small offset error (a few nT) will be present when switching between the x1 and x10 sensitivity settings. This in no way affects observation accuracy provided that the sensitivity setting is not changed during any set of four measurements per observation. If the audio null indicator is fitted, select an appropriate volume setting using the turn button fitted on top of the Mag-01H.

For this observation a reference target with a known azimuth (TA) is required. This is the angle subtended between the target and the Geographical Meridian (GM) at the point of observation. The target azimuth can be surveyed using GPS measurements.

The setting of the horizontal circle will be arbitrary; therefore, the target datum (TD) reading must be recorded first. With the circles unclamped, roughly align the telescope with the target

and clamp both circles. Then use the vertical and horizontal circle adjustment controls to align with the target.

1. Observe the target and record both the circle left (CL) and circle right (CR) horizontal circle readings. Calculate the target datum (TD) as follows:

$$TD(\pm 90^\circ) = (CL + CR)/2$$

Note: this contains a $\pm 90^\circ$ component which will be subtracted when calculating D.

2. Set the vertical circle to 90° or 270° as appropriate, ensuring the micrometer scale reads $00'00''$ (see Figure 9).. Perform the four null mode magnetometer observations and calculate the Magnetic Meridian mean value (MM).

$$\text{Where MM} = (ED + WD + EU + WU)/4$$

3. Calculate the Declination (D)

$$\text{Where D} = \text{MM} + (\text{TA}) - \text{TD} \pm 90^\circ$$

Select the value expected for D and reject the larger value.

Note: D will be positive if to the east and negative if to the west of GM. Observe correct use of brackets and signs.

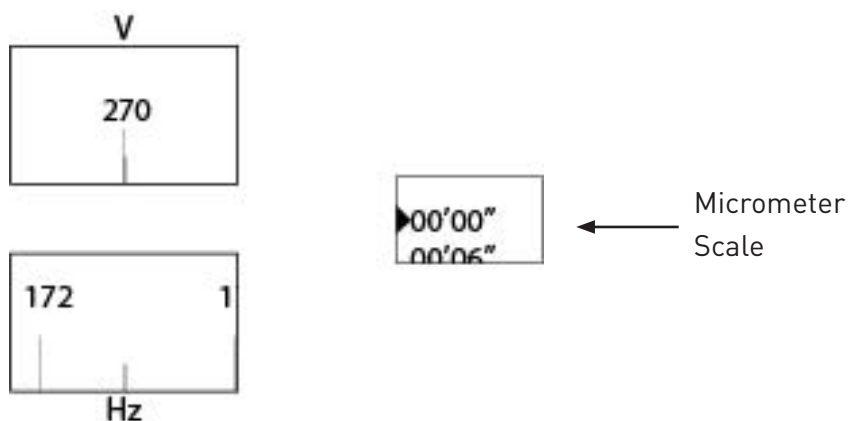

Figure 9. Magnetometer scale reading $00'00''$

Example (ideal observations):

If:

$$\begin{aligned} \text{TA} &= -30^\circ \\ \text{CL} &= 260^\circ \\ \text{CR} &= 80^\circ \\ \text{EU, WD} &= 14^\circ \\ \text{WU, ED} &= 194^\circ \\ \text{TD}(\pm 90^\circ) &= (CL + CR)/2 \\ &= (260^\circ + 80^\circ)/2 \end{aligned}$$

$$\begin{aligned}
 &= 170^\circ \\
 \\
 \text{MM} &= (\text{ED} + \text{WD} + \text{EU} + \text{WU})/4 \\
 &= (194^\circ + 14^\circ + 14^\circ + 194^\circ)/4 \\
 &= 104^\circ \\
 \\
 \text{D} &= \text{MM} + (-30^\circ) - \text{TD} \pm 90^\circ \\
 &= 104^\circ - 30^\circ - 170^\circ + 90^\circ = -6^\circ - \text{Select} \\
 &= 104^\circ - 30^\circ - 170^\circ - 90^\circ = -186^\circ - \text{Reject}
 \end{aligned}$$

6.6. Performing Observation of Inclination

For this measurement the reference direction is the compensated vertical scale.

1. With the probe on the top of the telescope, set the telescope NU to the mean value MM or (MM + 180°) on the horizontal circle, corresponding to the north observation of D, and lock the horizontal circle.
2. Rotate the telescope in the vertical plane and obtain the (NU) and (SD) null magnetic measurements.
3. Rotate the telescope to MM or (MM + 180°) on the horizontal circle, corresponding to the south observation of D. Lock the horizontal circle and rotate the telescope in the vertical plane to obtain the SU and ND null magnetic measurements.
4. Calculate the Inclination, I

$$\text{Where } I = [(360^\circ - \text{ND}) + (180^\circ - \text{SU}) + (\text{SD} - 180^\circ) + \text{NU}] / 4$$

Example (ideal observations):

If:

$$\text{ND} = 300^\circ, \text{SU} = 120^\circ, \text{SD} = 240^\circ, \text{NU} = 60^\circ$$

Then:

$$I = (60^\circ + 60^\circ + 60^\circ + 60^\circ) / 4 = 60^\circ$$

Note: [Appendix 1](#) is a suggested record sheet for use when performing observations. This may be copied by the user as required.

7. Repair and Maintenance

This section describes procedures for testing the Mag-01H D/I system, and for carrying out field adjustments to maintain full accuracy. Procedures for mounting the probe on the theodolite are included. Maintenance procedures are restricted to probe cable test and repair, and replacement of the Mag-01H battery.

Beyond this, no repair or servicing is possible with the Mag-01H D/I system. When service or maintenance is required, contact Bartington Instruments. However, a full calibration service is offered by Bartington Instruments, together with optional certification at an observatory.



Caution: The theodolite is not suited to operation under very wet conditions. If a theodolite has become wet then it should be wiped carefully and the container must be opened as soon as possible to allow the instrument to dry out completely. Never leave a damp theodolite in a closed container.



Caution: Rough handling should be avoided as the bearing journals in this type of theodolite are manufactured from phosphor bronze and are not as strong as those manufactured in steel.

7.1. Checking the System

7.1.1. Battery Check

Connect the battery charger to a live supply. The charge indicator on the magnetometer should illuminate.

After 10 to 20 minutes, switch on the magnetometer. The battery voltage is shown for a few seconds at switch-on and should be between 6.5V and 7V.

Disconnect the battery charger. Switch the magnetometer off and on again. The battery voltage should not be less than 6V. See also [Mag-01H Battery Replacement](#).

7.1.2. Functional Check

Set the sensitivity switch to x1. Vary the orientation of the probe with respect to the direction of the Earth's magnetic field. The LCD should respond with changes in sign and magnitude.

Orientate the probe so that the LCD indicates some low value, e.g. approximately 5nT (+0.005 μ T).

Momentarily select x10 sensitivity. The LCD should respond by displaying +0.050. Alternatively select $\pm 30\mu$ T using the offset control. The LCD should respond by $\pm 30\mu$ T.

7.1.3. Theodolite Optical Check

Eliminate optical errors. For the correct procedure, refer to the [Wild T1 manual](#).

7.2. Calibration

Return the D/I System to Bartington Instruments for magnetometer calibration at the recommended intervals. Refer to the Calibration Certificate for further details.

If mechanical misalignment is suspected during magnetometer calibration, Bartington Instruments' Service Department will contact you to suggest further tests. Mechanical misalignment resulting from wear and tear cannot be predicted, but additional periodic recalibration of the theodolite is recommended.

As a guide, offset errors should not exceed $\pm 5\text{nT}$ per annum.

7.3. Probe Cable Repairs

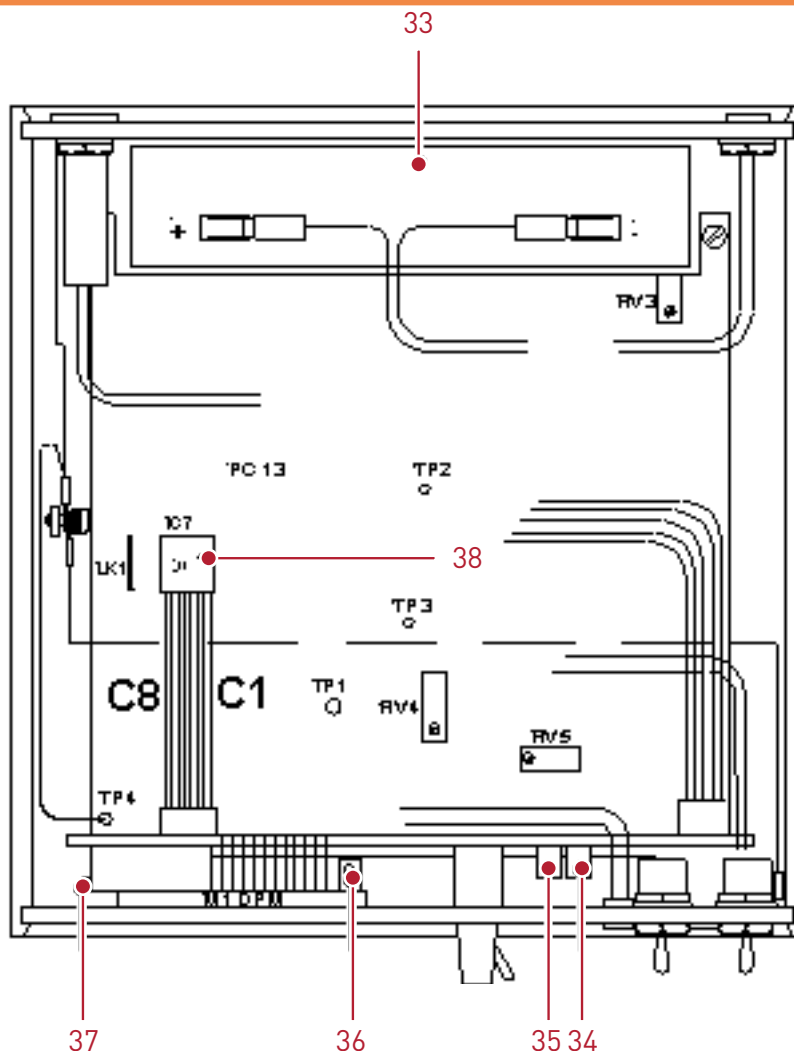

Figure 10. Mag-01H: internal view for cable replacement.

Key to Figure 10

- 33. Battery 6V 1.2Ah lead acid gel type
- 34. VR3 x1 O/S
- 35. VR2 x10 O/S. VR = variable resistor
- 36. DPM scaling

- 37. VR1 precision reference adjustment
- 38. Ribbon cable
- C1. Brown
- C8. Grey

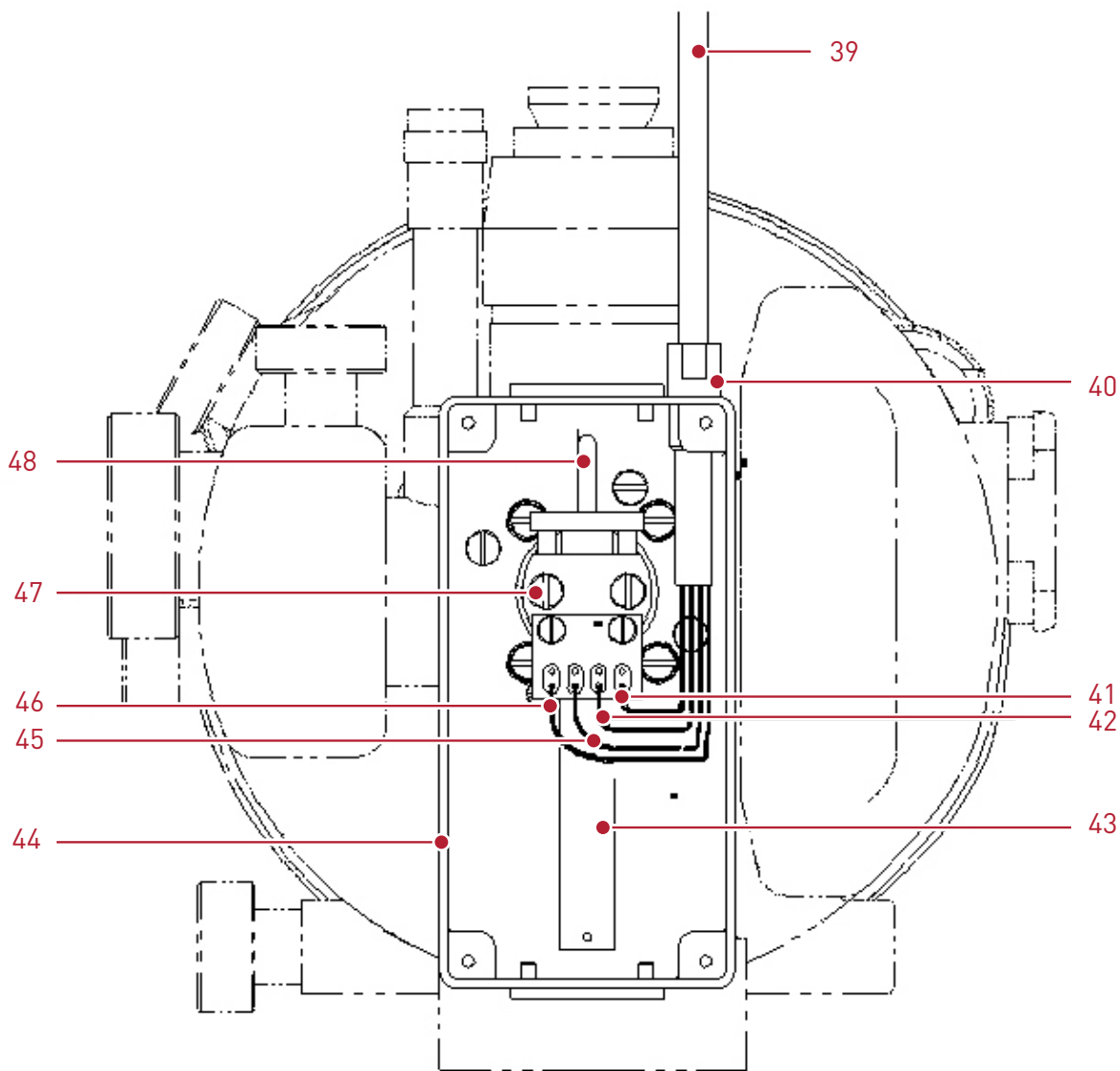

Figure 11. Mag A probe: internal view for cable replacement.

Key to Figure 11

- 39. 5m cable to magnetometer
- 40. Screw in cable head
- 41. Probe wiring cable – clear
- 42. Probe wiring cable - black
- 43. Fluxgate Mag A probe
- 44. Protective enclosure
- 45. Probe wiring cable – blue
- 46. Probe wiring cable – red
- 47. Probe mounting screws
- 48. Probe collimation joystick adjuster

See drawing DR0139, available on the product page, for details of the Mag A probe MOGAMI cable preparation and cable connections.

Should the cable fail due to fatigue or damage, the LCD will always read as if over-ranged. If the cable is suspected, check the electrical resistance using a suitable meter and with reference to the values in [Probe Electrical Resistance Values](#), below.

7.3.1. Replacing the cable

The cable can be replaced in the following way.

1. Remove probe cover screws.
2. De-solder the four wires from the tag strip.
3. Release the screw that retains the earth lead.
4. Unscrew the cable gland.
5. Reconnect in the reverse order.

7.3.2. Probe Electrical Resistance Values

Connections	Value (Ω)
+ Fb to - Fb	230 \pm 10
Ex to Ex	20 \pm 3

7.4. Mag-01H Battery Replacement

See Figure 10 for battery location.

If the battery fails then it can be replaced as follows:

1. Remove the top of the case.
2. Disconnect the push-on battery tags.
3. Remove the battery from the back panel clamp.
4. Install a new battery with the positive terminal to the left.

5. Re-connect the push-on battery tags, ensuring correct polarity.
6. Refit the top of the case.

7.5. Probe Alignment

The theodolite is set up in a site of known absence of magnetic gradients, less than 1nT per metre.

In this procedure the telescope is erected vertically and rotated about the horizontal axis, to discover and eliminate any errors due to differences between the magnetic and optical axis. Errors are removed using the joystick.

Accuracy of this setting will depend on the magnitude of the horizontal geomagnetic field H at the geographical latitude. This will be strongly dependent upon the Inclination angle I and will yield a resolution equivalent to that of dD . This procedure is unaffected by any residual offset errors.

For this procedure it is necessary to offset the vertical component Z of the geomagnetic field to obtain measurements with a resolution of 1nT.

7.5.1. Method

1. To gain access to the joystick, remove the protective cover at the cable gland end of the probe enclosure. The probe collimation joystick adjuster is clamped by two screws which act against a clamping plate at the base of the joystick. These screws should be slackened one half turn each using the non-magnetic screwdriver/adjusting tool (provided with each new system) to free the joystick. Some practice will be required to obtain the correct degree of slackness to permit adjustment.

Note: Standard screwdrivers may be magnetic and should be placed at least 4 meters distant when not required.

2. Carefully level the theodolite. Switch on the magnetometer and adjust to obtain high resolution. Set the vertical circle to precisely 180° using the vertical scale and note the reading on the Mag-01H.
3. Release horizontal circle and rotate the theodolite.
4. Record the position and magnetometer value for the maximum and minimum magnetometer readings. Calculate the mean of the two magnetometer readings: $(R1 + R2)/2$.
5. Set the direction of the theodolite to produce a maximum value and use the adjusting tool to move the joystick in a north-south direction along the magnetic meridian to obtain the mean value in (4).

6. Repeat steps (1) to (5), whilst gently re-tightening the clamping screws, until the difference between two readings and each pair of readings is circa 1nT. Light finger tightness only should be used.
7. Replace probe protective cover and four retaining screws.

7.6. Offset Trimming

See Figure 10 for reference. The electronics in the magnetometer unit must be exposed to perform this alteration as a potentiometer inside the casing must be adjusted.

1. Set up the theodolite as if to perform Inclination measurements.
2. Select the x10 range and set theodolite to position SU to achieve a null in I. Record this angular value.
3. Rotate vertical circle to a ND position to achieve null and record the second value.

Note: In the presence of an offset error these values will not be 180° apart.

4. Adjust the vertical circle to a value which is the mean of SU and ND: $(ND + SU - 180)/2$.
5. Adjust the x10 offset potentiometer (item 35 in Figure 10) to produce a displayed magnetometer value of 00000.
6. Select x1 sensitivity.
7. Adjust x1 offset potentiometer (item 34 in Figure 10) to produce a value of 0000.

7.7. Cleaning the D/I System



Caution: To clean the D/I System, use an air duster to blow out dust and debris if required. Use appropriate personal protective equipment (PPE), such as eye protection, when carrying out this task.



Caution: Avoid using chemicals such as solvents when cleaning the D/I System. Use a damp cloth to remove grime from external surfaces.



Caution: Take particular care when cleaning around electrical connections. Bent or damaged pins may cause the system to malfunction. The pins ONLY may be gently cleaned using a soft material dipped in Isopropanol (IPA). Avoid any contact with the rest of the

probe as this is likely to cause damage. Refer to the manufacturer's Material Safety Data Sheet (MSDS) for information on using this chemical safely.

8. Storage and Transport

Your sensor is a precision electronic instrument and should be treated as such.

Note: Avoid exposing this instrument to shocks or continuous vibration.

Note: Store only within the temperature range specified in the product brochure.

Note: Do not expose this instrument to strong magnetic fields while being stored.

Note: If the instrument is left to stand for a long period of time, move it to prevent magnetisation of the cores.

Note: If the instrument has been used in damp or wet conditions the theodolite and case must be allowed to dry before storage.



Caution: The theodolite should be stored in a dry environment. The theodolite must not be placed in an environment where condensation or moisture can deposit inside the unit (underneath a glass bell jar, or in a damp case), as this will promote the growth of mould. If this occurs then the alignment of the circle and optics can be affected.

Note: If storing the equipment in a permanently air conditioned environment, ensure that the theodolite has free flowing air around it, i.e. store outside of its case.

9. End of Life Disposal



This product should not be disposed of in domestic or municipal waste. For information about disposing of your sensor safely, check local regulations for disposal of electrical / electronic products. Alternatively contact Bartington Instruments to arrange the return of products for disposal. Where returning the instruments is not possible, you should check local regulations for disposal of electronic products.

9.1. Waste Electrical and Electronic Equipment (WEEE) Regulations

The Bartington D/I System complies fully with RoHS (Reduction of Hazardous Substances) legislation. However, electronic equipment should never be disposed of in normal waste.

Appendix 1: Observatory D/I Record Sheet

Observatory D/I Record Sheet

OBSERVATORY			
DATE			
OBSERVER			
T.A.	=	Degrees	Minutes
			Seconds

DECLINATION							
	Degrees	Minutes	Seconds		Degrees	Minutes	Seconds
CL				CR			

TD($\pm 90^\circ$) = (CL+CR)/2			
	Degrees	Minutes	Seconds
TD($\pm 90^\circ$) =			

NULL ANGLE HORIZONTAL CIRCLE				TIME T _D (UT)		
	Degrees	Minutes	Seconds	Hours	Minutes	Seconds
E.D.						
W.D.						
E.U.						
W.U.						

MM = (ED+WD+EU+WU) /4				MEAN-TIME T _D = (T _{ED} +T _{WD} +T _{EU} +T _{WU}) /4		
	Degrees	Minutes	Seconds	Hours	Minutes	Seconds
MM =				T _D =		

D = MM + (TA) - TD \pm 90						
D =	Degrees	Minutes	Seconds			

INCLINATION							
	Degrees	Minutes	Seconds		Degrees	Minutes	Seconds`
MM =				MM + 180°			
				=			

NULL ANGLE VERTICAL				MEAN-TIME T _I (UT)		
	Degrees	Minutes	Seconds	Hours	Minutes	Seconds
N.U.						
S.D.						
S.U.						
N.D.						

I = [(360°-ND)+(180°-SU) + (SD-180°) + NU] /4				MEAN-TIME T _I = (T _{ND} + T _{SU} + T _{SD} + T _{NU}) /4		
	Degrees	Minutes	Seconds	Hours	Minutes	Seconds
I =				T _I =		

Signed.....

Appendix 2: Example International Geomagnetic Reference Field

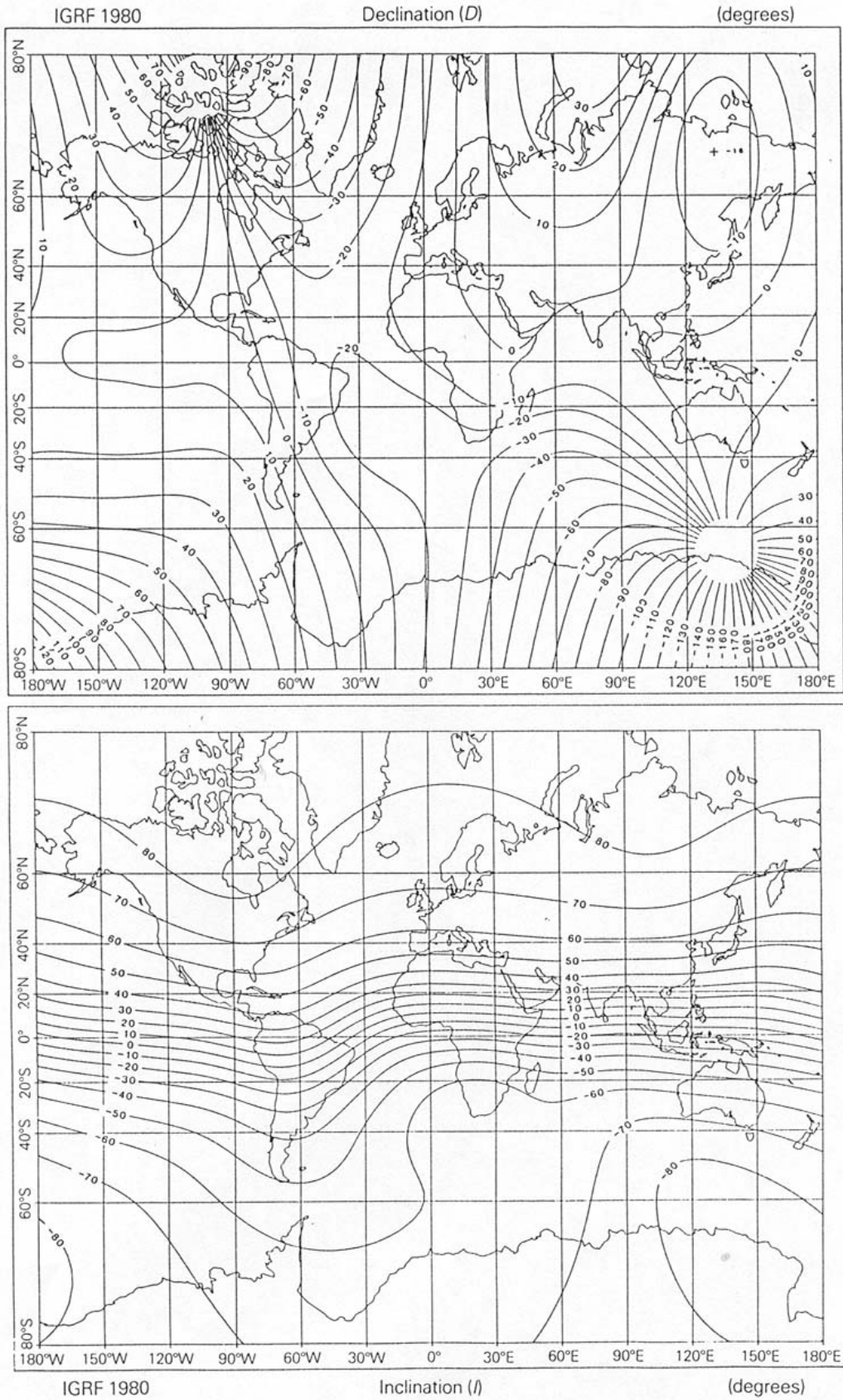

Figure A2.1. Example international geomagnetic reference field.



Bartington® Instruments

T: +44 (0)1993 706565
F: +44 (0)1993 774813
E: sales@bartington.com

Bartington Instruments Limited
5 Thorney Leys Business Park,
Witney, Oxford, OX28 4GE, England.

www.bartington.com

The copyright of this document is the property of Bartington Instruments Ltd.
Bartington® is a registered trade mark of Bartington Instruments Limited in the following countries:
United Kingdom, Australia, Brazil, Canada, China, European Union, India, Japan, Norway and the
United States of America.