



ROGOWSKI CURRENT TRANSDUCERS

INSTRUCTIONS FOR USE

LFR

Serial Number (I.D. No.): _____

Type: LFR ___ / ___ / ___

Distributed By:

GMW Associates

955 Industrial Road
San Carlos, CA, USA

PHONE: +1 650-802-8292 FAX: +1 650-802-8298

EMAIL: sales@gmw.com WEB: www.gmw.com

POWER ELECTRONIC MEASUREMENTS Ltd.

164 Lower Regent Street, Beeston, Nottingham, NG9 2DJ, U.K.

Tel: +44 115 925 4212 Fax +44 115 967 7685

Email: info@pemuk.com

CONTENTS

- 1. Introduction**
- 2. Technical specification**
- 3. Standards and approvals**
- 4. LFR Rogowski current transducer – Overview**
- 5. Safety and pre-use checks**
- 6. Battery supply, DC supply and output cables**
- 7. Installation and LFR transducer turn-on**
- 8. Obtaining the best measurement**
- 9. Cleaning and Decontamination**
- 10. Warranty**
- 11. Returning LFR's for recalibration or repair**

1. INTRODUCTION

The LFR is a dual range ac current probe with a flexible, clip-around coil. It provides a low voltage output proportional to the current being measured inside the coil.

The LFR product combines excellent low frequency performance, low noise and the minimum disruption to the circuit under test. These instructions should be followed whenever the unit is used. They are intended to help you obtain the best and safest performance from the transducer.

2. TECHNICAL SPECIFICATION

The LFR has the following specification (see front page for details of 'Type'):

Output Sensitivity									
	LFR	03/3	06/6	1/15	3/30	6/60	15/150	30/300	
<i>x1 range (mV/A)</i>		10	5	2	1	0.5	0.2	0.1	
<i>x10 range (mV/A)</i>		100	50	20	10	5	2	1	
Peak Current									
	LFR	03/3	06/6	1/15	3/30	6/60	15/150	30/300	
<i>x1 range (A)</i>		600	1200	3000	6000	12,000	30,000	60,000	
<i>x10 range (A)</i>		60	120	300	600	1200	3000	6000	
Noise									
	LFR	03/3	06/6	1/15	3/30	6/60	15/150	30/300	
<i>x1 range (mV rms)</i>		1.0	1.0	1.0	1.0	1.0	0.5	0.5	
<i>x10 range (mV rms)</i>		3.0	3.0	2.0	2.0	2.0	1.0	1.0	
Low Frequency (-3dB) Bandwidth									
	LFR	03/3	06/6	1/15	3/30	6/60	15/150	30/300	
<i>Hz</i>		0.45	0.23	0.15	0.10	0.08	0.07	0.07	
<i>Max 50Hz phase error degrees</i>		0.85	0.50	0.35	0.25	0.20	0.18	0.18	
High Frequency (-3dB) Bandwidth									
<i>LFR Coil length (mm)</i>		300	700						
<i>MHz</i>		1.0	0.6						
<i>Typical 20kHz phase error degrees</i>		1.8	3.0						
Operating temperature range	-10°C to +55°C electronics -20°C to +70°C coil								
Absolute max di/dt	6kA/μs								
Calibrated accuracy	±0.3% of reading with the test current central in the Rogowski loop								
Typical Positional accuracy	±1% of reading								

Temperature coefficient	-0.01 (coil) \pm 0.012 (integrator) % ^o C of reading
Power Supply	Single 9V PP3 battery - battery life typically 50 hours -plus- 2.1/2.5mm socket for 12V to 24Vdc (\pm10%) DC supply – (Quiescent current 10mA) <i>Battery inoperative with the dc supply present</i>
Peak Output	\pm 6.0V peak
Minimum load	100k Ω
Environmental	Indoor use / Altitude up to 2000m Installation Category III, pollution degree 2.

Dimensions

Plastic Enclosure: 28mm (H), 65mm (W), 90mm (D)
Rogowski Coil: 8.5mm cross section

Weight

Plastic Enclosure: 0.14kg
Rogowski Coil: 0.14kg

3. STANDARDS AND APPROVALS

EMC approvals	EN61326
Safety approvals	EN61010:2001 Safety requirements for electrical equipment for measurement, control and laboratory use

4. OVERVIEW: LFR- ROGOWSKI CURRENT TRANSDUCER

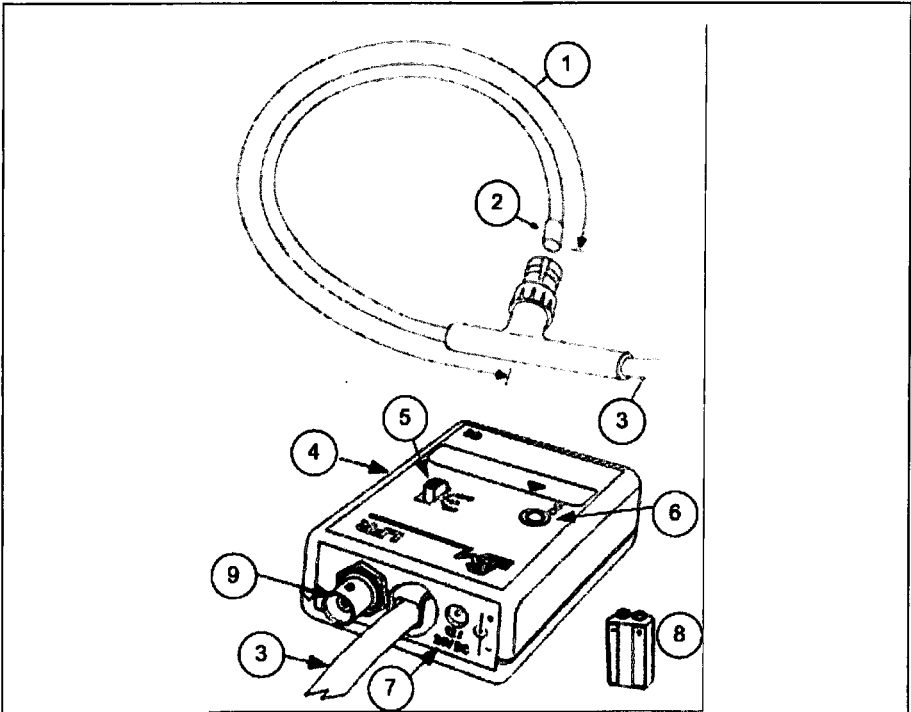

1. Rogowski coil (loop).
2. 'Free-end' of the Rogowski coil
3. Cable connecting the Rogowski coil to the integrator - low noise co-axial cable.

The Rogowski coil and connecting cable have double or re-enforced insulation.

4. Plastic enclosure housing the electronic integrator.
5. Power on / Range switch to alter the transducer sensitivity (mV/A).
6. Power on / Battery Low Indicator
 - Green LED: LFR on
 - Red LED: low battery
7. Socket for external DC supply
8. Single 9V PP3 battery
9. Output BNC socket

5. SAFETY AND PRE-USE CHECKS

Throughout this instruction sheet there are a number of warnings which must be observed to ensure safe operation of this unit. These warnings are identified by the following symbol:



PEM accepts no responsibility for any accidents or damage resulting from careless use, or non-observance of these instructions.

THE ROGOWSKI COIL



It is recommended the Rogowski coil is not installed on a live conductor. If the Rogowski coil is installed on a live conductor the user is responsible for taking sufficient safety precautions to avoid harm by hazardous voltages.



The integrity of the insulation around the Rogowski coil itself should be **VISUALLY INSPECTED** before use, and the unit should **NOT BE USED** if there are signs of damage.



When bending the flexible coil around a conductor, avoid tight bends and sharp edges that could damage the coil.



The voltage rating (safe **PEAK** working voltage) is clearly labelled on the coil. The rating is 2kV peak.

The rating is derived from the following standard test: All LFR coils supplied by PEM including the ferrule connecting the coil to the cable are flash tested for 1 minute at 4kVrms using a 50Hz sinewave.



For permanent installation the coil should be situated such that corona, which would eventually damage the coil insulation, cannot occur. For information regarding permanent installation of PEM's Rogowski coils on high voltage equipment please consult PEM.



Voltage ratings are only valid if the 'free-end' of the coil is fully inserted into the socket, and remains fully inserted during use.

The 'free-end' will be fully inserted when the user feels the free-end of the coil engage with the jaw mechanism of the ferrule. Visual indication that the free-end is fully inserted is provided by the black marker situated near the end of the coil.

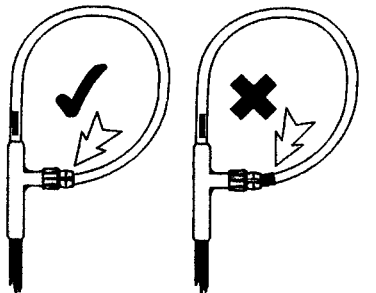



If the coil is to be left in-situ for any period of time or is used in an environment where the coil is subject to vibration the locking nut should be engaged as shown in the diagram below.

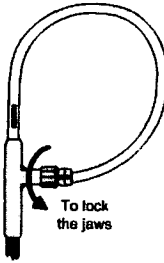

THE INTEGRATOR



The LFR must be used with oscilloscopes or monitoring equipment which have their BNC INPUTS PROPERLY GROUNDED.

6. BATTERY SUPPLY, DC SUPPLY & OUTPUT CABLES

The LFR can be powered by an external DC SUPPLY or a 9V PP3 battery.

The DC SUPPLY accepts a 2.1/2.5mm plug and the input polarity is labelled on the end plate. The battery supply is disconnected when the external DC supply is fitted.

BATTERY SUPPLY

Battery Installation



Never change the battery with the Rogowski coil installed around a live conductor and do not operate the LFR with the battery panel removed.



Always disconnect the DC power supply when changing the battery

The LFR battery should be replaced when the red indicator LED is illuminated or when the indicator LED fails to illuminate in the ON position.

Remove the Rogowski coil from around any current carrying conductor and disconnect the DC supply. Ensure that the output from the LFR is disconnected from any external equipment.

The battery cover on the back of the enclosure can now be removed and the battery can be changed. Replace the battery cover before use.

DC SUPPLY - Explanation of symbols identifying the DC SUPPLY connections



Direct current



Positive / Negative terminals

The DC power supply which should have a CE mark if the customer requires this certification.



The DC supply should be fused and have an isolation voltage of greater than 4kV

OUTPUT CABLES - Explanation of symbols identifying the OUTPUT connections



Voltage signal out.

The LFR is supplied with a 0.5m co-axial output cable. For best operation a short length <3m of 50 ohm co-axial cable should be used to connect the LFR output to the load. Although at present this has not been included in the immunity tests and may decrease RF noise immunity, PEM does not consider the use of long cables (> 10m) to be problematic from the noise viewpoint. PEM has conducted tests using a 25m extension and no discernible attenuation of measured current signal has occurred although, as is to be expected, there is an increased measurement delay of 5ns/m

7. INSTALLATION AND TURN-ON



Before installing the LFR and taking a measurement the **SAFETY AND PRE-USE CHECKS MUST BE FOLLOWED** to ensure safe operation of your LFR.



It is recommended the Rogowski coil is not installed on a live conductor. If the Rogowski coil is installed on a live conductor the user is responsible for taking sufficient safety precautions to avoid harm by hazardous voltages.

1. Connect the BNC output of the LFR to your oscilloscope or monitoring equipment using the 0.5m BNC cable provided, or a suitable alternative.
2. Connect the external dc supply (if using)
3. Turn the LFR ON by selecting the desired transducer peak current (x1 or x10 range) using the **Power on / Range** switch.
4. After switch-on the LFR requires a short period to settle and attain its quiescent state before providing correct current measurement. The time, which depends on low frequency bandwidth, can be as long as 2 minutes.
5. Having carried out the visual inspection of the Rogowski coil, un-clip the coil and wrap the Rogowski coil around the de-energised conductor under test. Ensure that the free-end of the coil is fully insert into the connector as described in "5. Safety and pre-use checks".
6. The user is now ready to re-energise the conductor under test and take measurements.

8. OBTAINING THE BEST MEASUREMENT

The Rogowski coil should be positioned so that the conductor under test is encircled by the coil but is not adjacent to the cable attachment (see picture below). The diagram below shows the direction a positive current should pass through the coil loop in order to obtain a positive output voltage. The LFR has been calibrated with the conductor near the centre, and this is the ideal position.

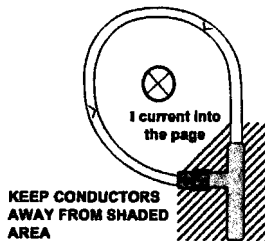

The sensitivity of the LFR to currents that do not pass through the coil is very small, provided that such currents are no greater than the LFR rating or such currents are relatively distant from the coil. In the vicinity of a multi-turn inductor the 'H' field is far stronger than from a single conductor carrying the same current, and such positions should be avoided.

Similarly if there is a surface with a high voltage very close to the coil, and the voltage is subject to high rates of change (e.g. several 100 V/ μ s) or high frequency oscillations in the MHz range, then measurement error can arise due to capacitive coupling to the coil.

As a check on any unwanted response to adjacent fields, it is wise to display the output of the LFR when close to (but not encircling) the conductor whose current is to be measured. This will reveal the magnitude of any unwanted response to currents close to but outside the coil.

9. CLEANING AND DECONTAMINATION

To prevent surface contamination of the Rogowski coil and cable inspect regularly. To clean the coil and cable use a mild detergent and water to remove any contamination, wipe with clean water to remove the detergent and dry thoroughly with a clean cloth. The LFR must be disconnected from any external circuit prior to cleaning.

PEM accepts no responsibility for the use of any other cleaning solvents or cleaning methods.

10. WARRANTY

The coil is guaranteed to be free from defects due to materials and workmanship for 12 months and the integrator for 24 months from the date of despatch from Power Electronic Measurements Ltd. In the event of a defect or incorrect operation of the unit where the transducer has not been misused the LFR should be returned to PEM with all freight charges to be paid by the customer. Correction shall be in the form of repair or replacement.

11. RETURNING *LFR*'s FOR RECALIBRATION OR REPAIR

If it is necessary to return the LFR to PEM for repair whether or not under warranty please contact PEM in advance for shipping instructions (see below for contact details). To facilitate customs clearance it is important to follow the correct procedure otherwise import tax will be charged. PEM will not accept units sent for recalibration or repair if the relevant procedure is not followed.

For technical updates or enquiries and the latest product releases please consult

www.pemuk.com

POWER ELECTRONIC MEASUREMENTS Ltd.
164 Lower Regent Street, Beeston, Nottingham, NG9 2DJ, U.K.
Tel: +44 115 925 4212 Fax: +44 115 967 7685
Email: info@pemuk.com