

## GMW360ASM

### Angle Sensor Module

#### FEATURES

- Analog and PWM outputs for 0 to 360 degrees
- 10% to 90% active range output signals
- Resolution of up to 9 bits
- Magnet “Out of Range” discrete output
- User selectable “Zero Angle” set
- No external parts required
- Single 5V supply
- Small 1/2” dia encapsulated package

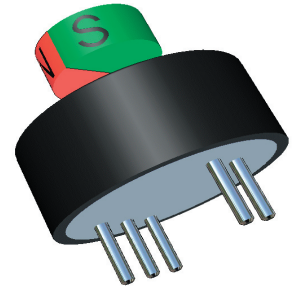

#### GENERAL DESCRIPTION

The GMW360ASM is a non-contact 360 degree absolute angular position sensor. The GMW360ASM provides an Analog and PWM output signal which is proportional to the mechanical angle of a magnet with a resolution of 0.75 degrees. In addition to the absolute angle position outputs, the GMW360ASM detects when the field strength of the magnet is too low and provides a discrete “Magnet Out of Range” signal. The electrical “Zero Angle” position can be set to correlate to any mechanical position within 360 degrees. This is accomplished by momentarily connecting the Analog Output pin to the +5 Volt supply and applying power.

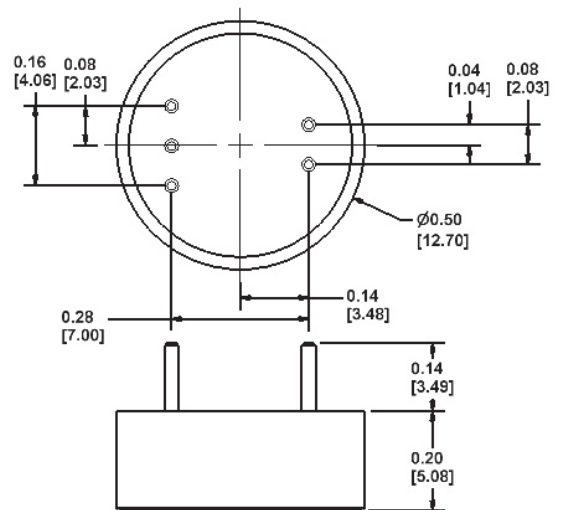
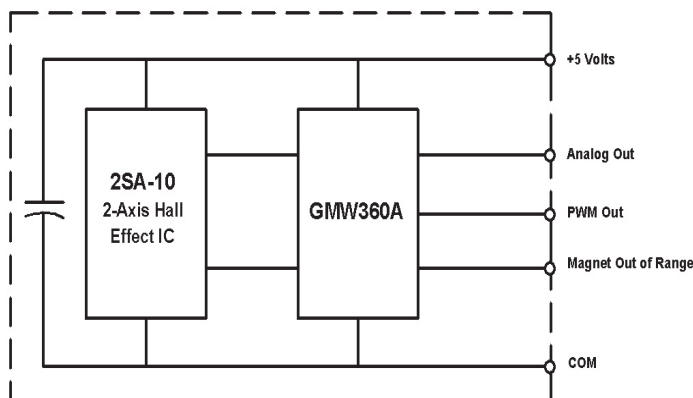

Fig.2 Block Diagram



PWM OUT  
MAG OUT  
A OUT  
+5 V  
COM

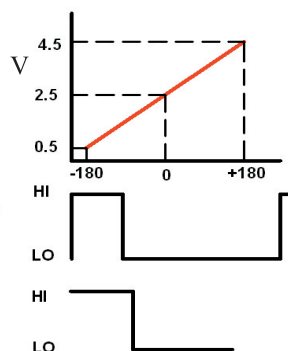

Fig. 1 Bottom View of Module

## SPECIFICATIONS

### Absolute Maximum Ratings

Symbol	Parameter	Min.	Typ.	Max.	Unit	Remarks
T <sub>STG</sub>	Storage Temperature	-55		100	°C	
T <sub>A</sub>	Ambient Temperature	-40		85	°C	With power applied
V <sub>SUP</sub>	Supply Voltage	-0.5		+6.0	V	
V <sub>IO</sub>	DC Input Voltage	V <sub>COM</sub> -0.5		V <sub>SUP</sub> +0.5	V	
I <sub>MIO</sub>	Max current into any pin	-25		+50	mA	
ESD	Electro Static Discharge	2000			V	Human Body Model ESD
B	Magnetic Field			1	T	Tesla

### Recommended Operating Conditions

Symbol	Parameter	Min.	Typ.	Max.	Unit	Remarks
V <sub>SUP</sub>	Supply Voltage	4.5	5.0	5.25	V	5.0V ± 0.25 with 2SA-10

### Electrical Characteristics

Operating Conditions: V <sub>Sup</sub> = 5.0 V and T <sub>A</sub> = 25° C	
Note (1): Outputs are ratiometric to the supply voltage V <sub>SUP</sub>	
<b>Outputs:</b>	
Analog output-Pin 1:	0.5 V to 4.5 V <sup>(1)</sup> (0 deg to 360 deg- See Output Plot)
Analog output current:	± 1 mA max
PWM output - Pin 5:	10 % to 90 % <sup>(1)</sup> duty cycle (0 deg to 360 deg)
PWM output voltage:	Low = 0.75 volts max @ IOL=25 mA High = V <sub>SUP</sub> -1.0 V min @ IOH=10 mA
PWM Frequency:	2 kHz
Magnet "Out of Range Pin 3	HI when magnet is "in range" LO when magnet is "out of range "
Magnet "Out of Range IOL:	25 mA max
Magnet "Out of Range IOH:	10 mA max
<b>Inputs:</b>	
Zero Angle :	Active High > 4.75 volts prior to V <sub>SUP</sub> application (Max voltage not to exceed 6 Volts)
<b>Zero Angle set analog voltage:</b>	2.50 ± 0.01 volts <sup>(1)</sup>
<b>Zero Angle set PWM duty cycle:</b>	50 % ± 0.4 % <sup>(1)</sup>
<b>Response Time:</b>	≤ 5 mS (Time to sample inputs and perform angle calculation)
<b>Resolution:</b>	9 bits
<b>Accuracy:</b>	± 1 deg

### Magnetic Specifications

Maximum Horizontal Field:	45 mT at surface of module
Minimum Horizontal Field:	Below 6 mT Magnet "Out of Range" will be activated

Revision Date: 26 May 2005 GMW360ASM\_SPEC

## FUNCTIONAL OPERATION

**Zero Angle set command** - The electrical output of the module for the zero angle position can be set to match any mechanical position of the magnet within the 360 degree rotation. This feature eliminates the need to mechanically align the position of the sensor output to the mechanical position of the rotating target. The zero angle output is 2.5V for the Analog Output and 50% Duty Cycle for the PWM output. The Zero Angle set function is initiated by providing a momentary connection between the Analog Output pin and the 5V supply prior to applying power to the module. Once power is on for more than 100 ms, the momentary connection is removed and a 100 ms "Zero Angle" calculation is initiated. At the end of the 100 ms time, the GMW360ASM is operational and the Analog Output will be set to 2.5V and the PWM output will be set to 50 % Duty Cycle. The Zero Angle set point is permanently stored into flash memory and remains there until a new Zero Angle command is initiated. The maximum number of changes to this set point is 50,000

**GMW360A Output Characteristic**

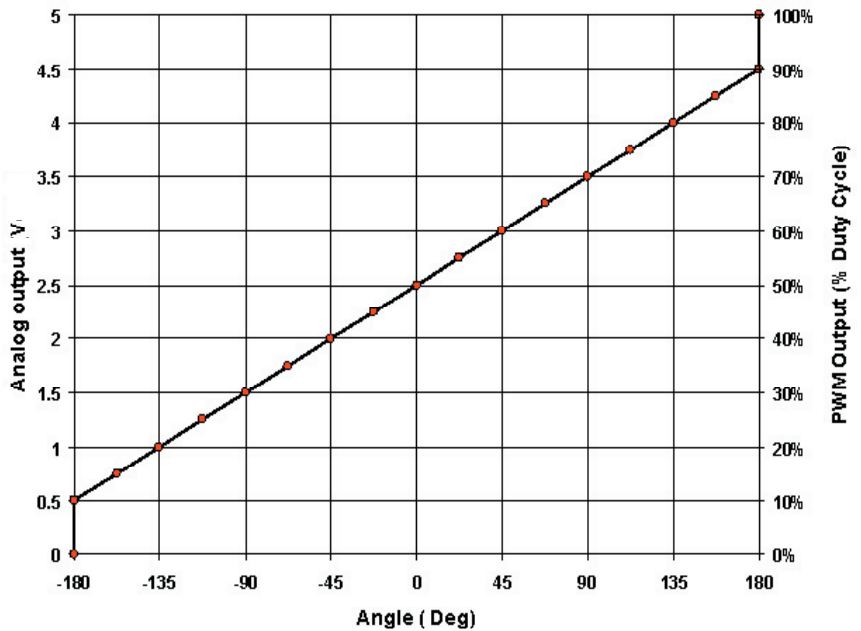

**Figure 3 - GMW360ASM Output characteristics**

The Zero Angle set point is permanently stored into flash memory and remains there until a new Zero Angle command is initiated. The maximum number of changes to this set point is 50,000

**Caution:**

*The output pins must not be exposed to voltages larger than the maximum specified voltage of 6.0V or damage to the module may occur*

**Magnet "Out of Range"** - This output will be activated when the magnetic field strength at the surface of the module drops to approximately 6 mT. The output will go to the LO state and can be used to drive an LED or be used as a diagnostic signal to a controller.

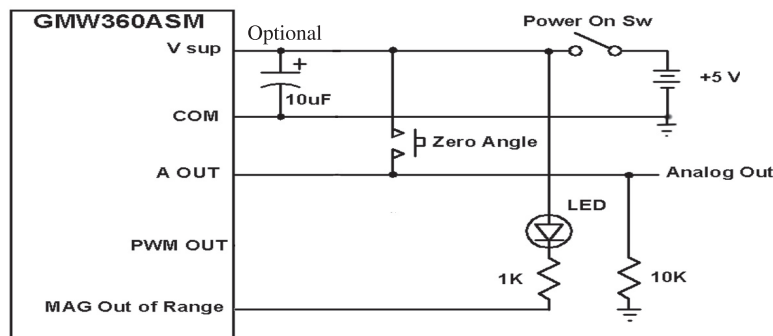

**Figure 4 - Typical Connection Diagram for GMW360ASM**

Revision Date: 26 May 2005 GMW360ASM\_SPEC

## APPLICATION HINTS

**Power supply capacitance** - The module has internal power supply capacitance, however if needed to reduce the noise on the power line, an additional 1uF to 10uF capacitor can be connected near the GMW360ASM between +5V and COM.

**Output Loads** - For normal operation, do not connect the outputs to an active high load. If the outputs (Analog and PWM) are held high during the power on, the Zero Angle set and the internal Offset Null routines may be initiated. Loads should be referenced to Common.

**Magnet Targets** - The GMW360ASM can work with many different magnet shapes and sizes as shown in Figures 5 thru 8. The module senses field vectors that are parallel with the top surface of the module. The direction of the field vector is converted to angle output as an analog voltage or PWM (Pulse Width Modulated) signal. The distance between the magnet and the surface of the module is referred to as the “Air Gap” and this distance is dependant on the size and strength of the magnet. The maximum strength of the horizontal field should not exceed 45 mT (450 Gauss) at the surface of the module. For example a GMW P/N 55B0082, SmCo 24 magnet, 6 mm in dia and 4 mm thick shown in Fig. 5 will have a minimum air gap of approximately 2.5 mm and a maximum air gap of approximately 5 mm.

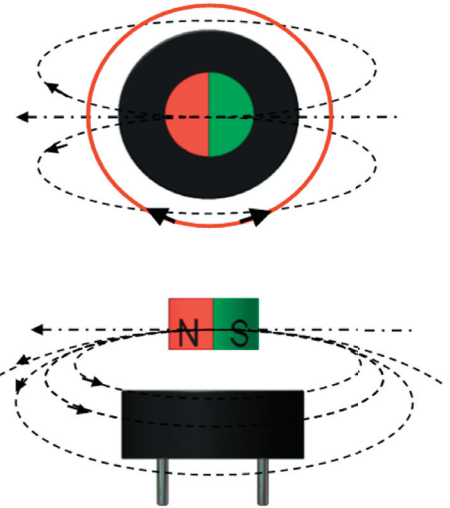

Fig. 5 Disc Magnet

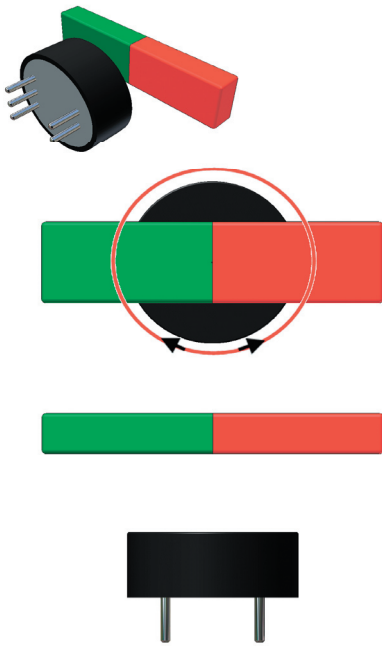

Fig. 6 Bar Magnet

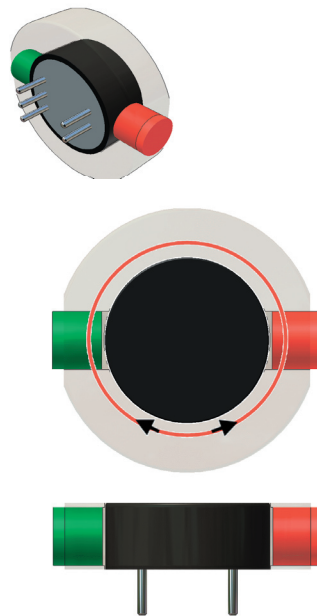

Fig. 7 Radial Magnets

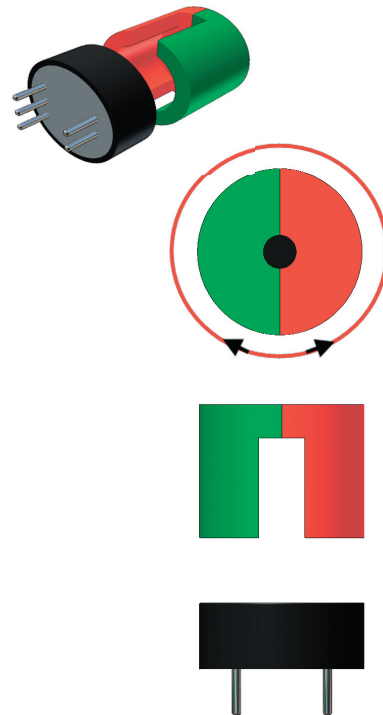

Fig. 8 Holding Magnet

Revision Date: 26 May 2005 GMW360ASM\_SPEC