



AN_180KIT for AKM HG-106C-2U Hall Element Y axis, Thin, High Magnetic Field Sensor

General Description

The AN_180KIT takes advantage of the very special lead frame and size of the AKM HG-106C-2U, GaAs, Hall element to detail the method of making a very thin (<0.65mm) thick, high field (+/-1T) magnetic field sensor. The kit incorporates a thin 0.4mm thick PCB and includes all the circuitry to interface with the Hall element. For the most temperature stable output, the HG series Halls should be driven with a constant current source. This kit has a current source of 0.5mA and an instrument amplifier to increase the Hall element output signal to a full scale analog voltage of 2.5V +/- 1.5V for a magnetic field up to +/-1.5T. The output is linear to a magnetic field of +/-1T.

To provide a stable output independent of the power source regulation, an internal voltage regulator is provided. The input voltage can vary between 4.25V and 6V without affecting the sensor sensitivity. A 5m small flexible cable with three leads is included.

The Sensitivity and Offset are not calibrated in this kit, however the actual Offset voltage and Sensitivity are measured and are printed on the label. Any required calibration of these parameters could be accomplished by measuring the output when exposed to known fields and storing the values in a microprocessor or equivalent post processing.

The AKM HG-106C-2U has a special lead frame which incorporates straight leads, allowing the Hall element to be mounted into a PCB slot, thus reducing the overall height of the assembly. See illustration on page 2.

The Field Sensor PCB is very flexible and the small size of the tip enables evaluation of the HG-106C-2U for the measurement or control of the magnetic field in assemblies such as loud speakers, inductors, magnetic actuators, current sensors and electric motors or generators.

Specifications:

- Measures transverse magnetic field component (By)
- Linear magnetic field range: $B_y = \pm 1T$ *
- Sensitivity: 1mV/mT +/- 15%
- Output voltage range: 2.5V +/- 1.20V
- Output at $B_y=0$: 2.5V +/- 150mV.
- TC of Sensitivity: -0.06%/°C
- Frequency range: 0 to 20kHz
- Maximum sensor tip thickness: 0.62mm
- Cable: 5m flexible, PVC jacket with three, 28AWG conductors. (diameter: 1.5mm)
- Operating voltage: 4.25V to 6.0V at 1.5mA
- Sensor pcb tip length/width: 60mm x 4mm
- Operating temperature: 25°C +/- 25°C

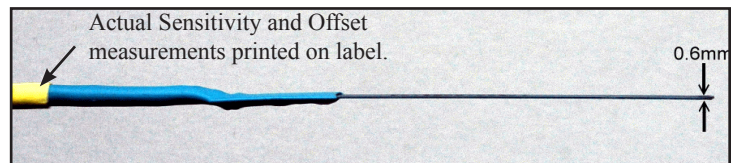

* Lower maximum field ranges and higher sensitivities are available by Hall current and amplifier modifications

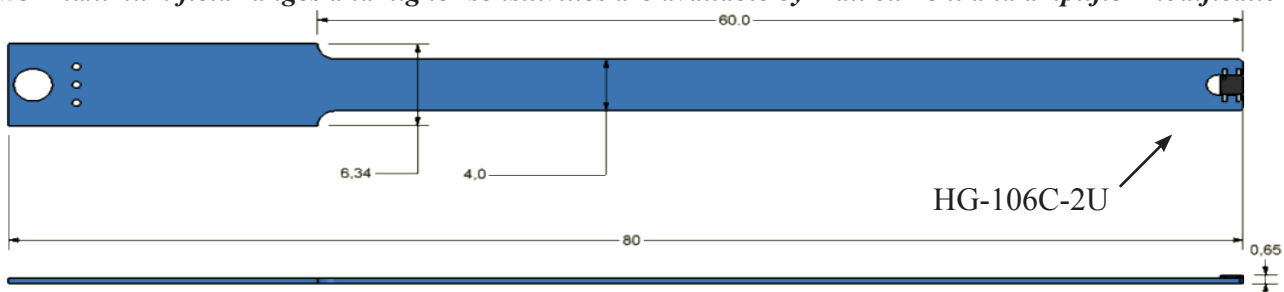

AN_180KIT PCB dimensions (mm)

Revision Date: Sept 27, 2016



AN_180KIT for AKM HG-106C-2U Hall Element Y axis, Thin, High Magnetic Field Sensor

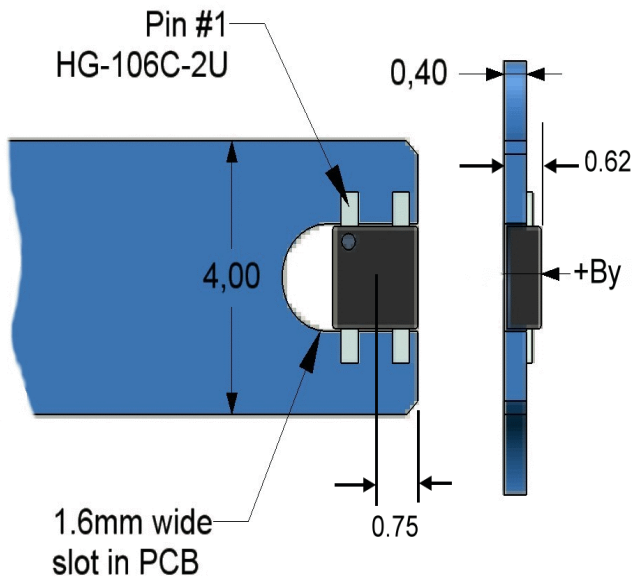

The AKM HG-106C-2U's unique package with the leads protruding straight out from the package allows a method of mounting the chip into a slot on the PCB. By using a thin 0.4mm PCB the over all height can be reduced to a 0.65mm . If the IC had standard Gull wing leads, the min. height would only be 0.4mm + 0.60mm = 1.0mm

Note: The probe's components thickness of maximum 0.65 mm may be increased by the presence of sealant material that can be removed if necessary.

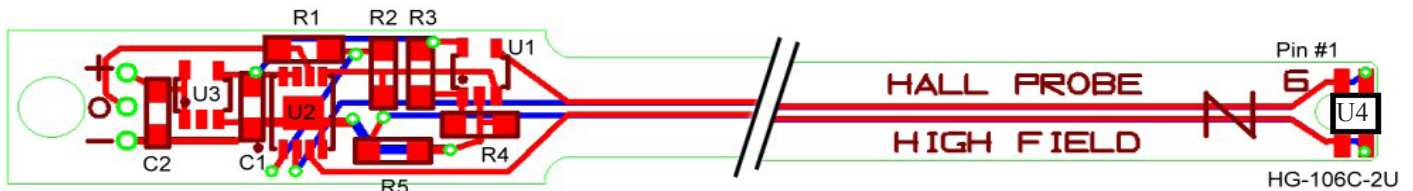

Parts List and component cost*, AN_180KIT (excluding cable)

Ref Des	Qty	Description	Mfgr Part #	MFGR	Cost ea. @1K
U1	1	Gen Purpose, Low V, R R OpAmp	LMV321M7	National	\$0.33
U2	1	500kHz,800uA, Instrument Amp	MCP6N11-005	Microchip	\$1.02
U3	1	150mA, Tiny CMOS LDO 4V	TC1017-4.0VLT	Microchip	\$0.30
U4	1	Hall Effect Element	HG-106C-2U	AKM	\$0.53
C1	1	CAP CER 1UF 10V Y5V 0603	C1608Y5V1A105Z	TDK Corp	\$0.01
C2	1	CAP CER 0.1UF 25V 10% X7R 0603	C1608X7R1E104K	TDK Corp	\$0.01
R1	1	RES 200K OHM 1/10W 5% 0603	ERJ-3GEYJ204V	Panasonic-ECG	\$0.01
R2	1	RES 17.4K OHM 1/10W 1% 0603	ERJ-3EKF1742V	Panasonic-ECG	\$0.01
R3	1	RES 30.1K OHM 1/10W 1% 0603	ERJ-3EKF3012V	Panasonic-ECG	\$0.01
R4	1	RES 49.9K OHM 1/10W 1% 0603	ERJ-3EKF4992V	Panasonic-ECG	\$0.01
R5	1	RES 4.99K OHM 1/10W 1% 0603	ERJ-3EKF4991V	Panasonic-ECG	\$0.01
PCB	1	PCB, 0.4mm Thick, FR4	AW 14900-2069-03	GMW	\$0.92
Total					\$3.16

* all costs are approximate and for quantities of 1000

Revision Date: Sept 27, 2016

GMW Associates: 955 Industrial Road, San Carlos, CA 94070, USA. www.gmw.com. +1 (650) 802-8292

Schematic, AN 180KIT (circuit values for +/- 1T field range)

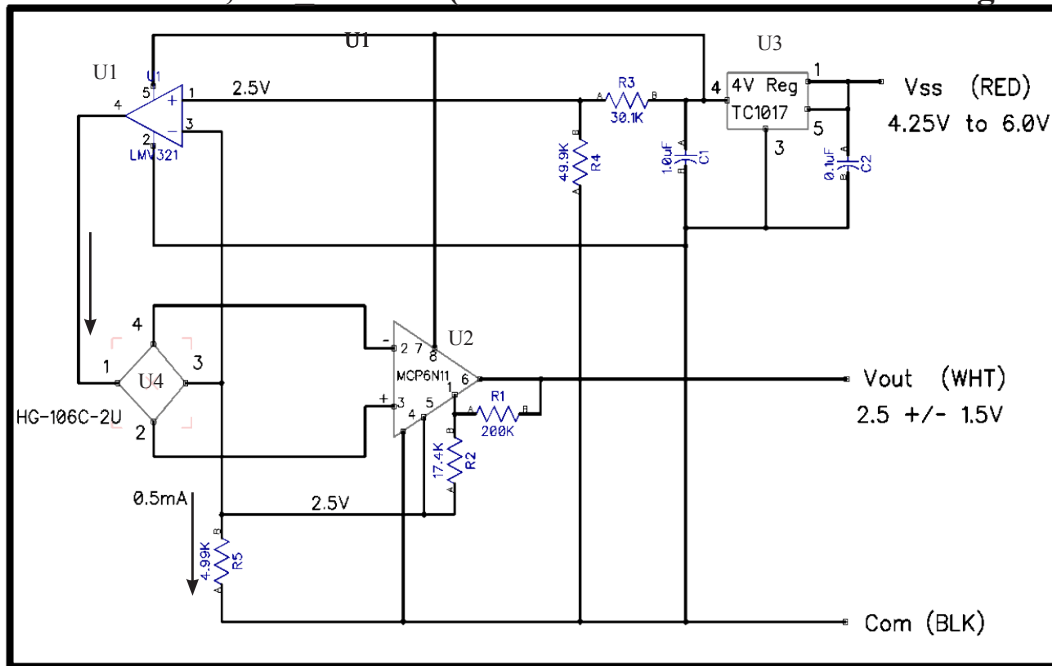

AN_180KIT Circuit Description

The Hall Kit is powered by a 4.25 to 6.0V supply. This input voltage is regulated to 4.00V with a small LDO, the MicroChip TC1017. This regulated voltage provides a stable operating supply for the sensor electronics. C1 and C2 are required to stabilize the voltage regulator. The resistor divider, R3 and R4 provide a reference voltage of 2.5V for the constant current supply circuit consisting of U1 and R5. With Pin of U1 at 2.5 Volts, the output of the op-amp drives a current into the Hall IC, HG-106C-2U input pins 1&3, resistor R5. The current through R5 creates a voltage that is connected to pin 3 of the op-amp, U1. When the current reaches a point where the voltage across R5 is 2.5V, then the U1 op-amp starts turning off. The op-amp will maintain a constant 2.5V across R5. With the voltage being constant across R5, the current thru it and thru the Hall IC remains a constant 0.5mA ($2.5V/4.99k = 0.5mA$). The instrumentation amplifier, U2, amplifies the Hall voltage from U4, pins 2&4. The Hall voltage output can be calculated as follows:

Calculating the Hall element output level and amplifier gain

From the HG-106C-2U spec sheet, the typical Sensitivity (V_H) = 65mV/50mT @ 6V or 1.3mV/mT @ 6V. Since we are using a current drive rather than a voltage drive, the equivalent sensitivity for I drive would be 50mV/50mT @ 6mA drive (derived from curve " V_H-V_C, V_H-I_C " on page 2 of the spec sheet) and B=50mT. The drive current used in this application kit is only 0.5mA, therefore the "By" sensitivity level of the Hall element output (Pins 2&4) will be approximately. $(48mV/50mT) * (0.5mA/6mA) = 0.080mV/mT$.

Our target is 1mV/mT, therefore the gain of the instrumentation amplifier needs to be $1/0.08=12.5$.

The instrument amplifier gain is determined by R1 and R2. The equation is $G=(1+R1/R2)$. If the G needs to be 12.5, then $R1/R2 = (12.5-1)=11.5$. If R1=200K, then $R2 = 200/11.5=17.4K$. R2 can be adjusted up or down to provide more accurate calibration of the sensor.

Revision Date: Sept 27, 2016



AN_180KIT for AKM HG-106C-2U Hall Element Y axis, Thin, High Magnetic Field Sensor

The $V_{in}=0$ referenced voltage for the instrument amplifier output voltage is established by the voltage at pin 5 of U2. This voltage is supplied by the relatively low source impedance voltage at R5 (2.5V). With the reference voltage set at 2.5 volts, the output voltage will nominally be the same (2.5V) when $V_{in}=0V$. V_{out} of the amplifier will be $2.5V \pm V_{in} * Gain$ (12.5)

Determine the maximum By Field for linear operation.

The maximum B_y for linear operation is approximately 25% of the Hall Input voltage. The R_{in} of the Hall element is normally 750 ohms, and with 0.5mA drive current, the Hall input voltage will be approximately $750\Omega * 0.5mA = 375mV$. 25% of 375mV is 94mV. We calculated the Hall sensitivity to be approx 0.08mV/mT, therefor the max B will be $94mV / 0.8mV/mT \approx 1200mT$ or 1.2T. Below is actual data from a kit that shows the output to start saturating around 1.1T

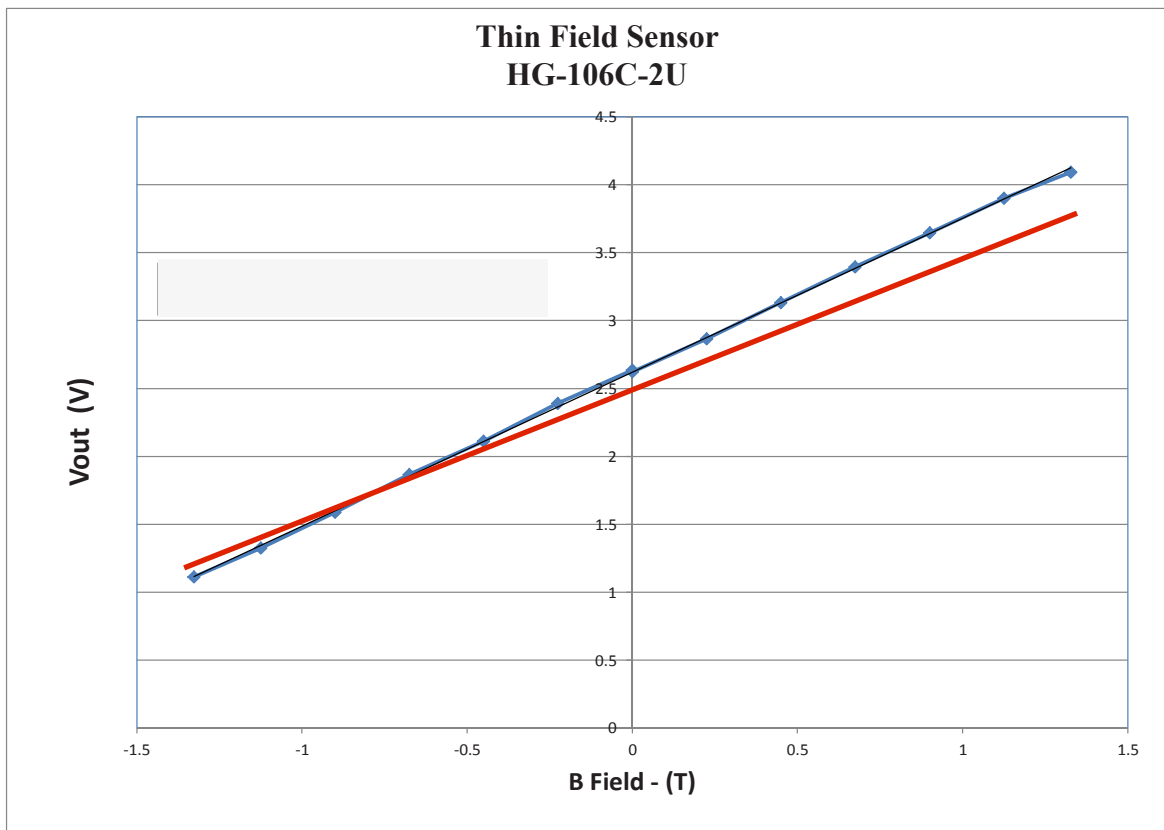

Typical output curve for V_{out} vs B field (Blue) compared to the nominal curve with $V_{out} = 2.5V$ at $B=0$ and Sensitivity = 1mV/mT curve (Red)

Ordering information

Part number: AN_180KIT, Y Axis. Thin, High Magnetic Field sensor

Gerber File for PCB: Email <Sales@gmw.com> and request a copy of AW14900-2069-03.

Revision Date: Sept 27, 2016