

PROPRIETARY
 THIS DRAWING CONTAINS CONFIDENTIAL
 INFORMATION PROPRIETARY TO GMW INC. IT MUST
 NOT BE REPRODUCED OR DISCLOSED TO OTHERS OR
 USED IN ANY OTHER WAY, IN WHOLE OR IN PART
 EXCEPT AS AUTHORIZED IN WRITING BY GMW INC.

9mm±.3mm dia.

1,25 ± 0,10

14mm±.4mm dia.

5,00 ± 0,20

Material: Type 22G
 Source: Kolektor Magma d.o.o
 Stegne 29, 1521 Ljubljana
 Slovenia
 Email: magma@kolektor.si

Kolektor Part Number:
 T22G-14-09-5-1.25

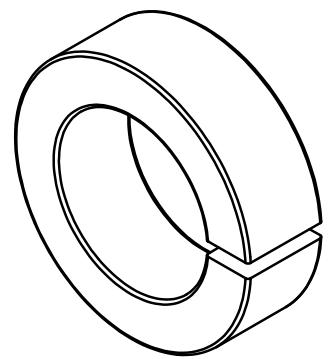

DRAWN	Date	DO NOT SCALE FROM DRAWING DIMENSIONS & TOLERANCES UNLESS OTHERWISE SPECIFIED	GMW Associates 955 Industrial Road, San Carlos, CA 94070 Tel: (650) 802-8292. Fax: (650) 802-8298		
CHECK	Date		LINEAR	INCHES	mm
ENGINEERING	Date		X.XXX	±.005	±0.03
			X.XX	±.01	±0.1
		X.X	±.03	±0.3	
		X	±.06	±1	
		DEG.	±.5	±0.5	
		FINISH	63	1.6	
THIRD ANGLE PROJECTION		SIZE	DRAWING No.		
		A3	12900-2813-0		
		SCALE:	WT:	kg	
			SHEET:	OF:	

Ferrite Core with 1.25mm gap
14mm x 9mm x 5mm